

# FWC AIRBOAT OPERATOR COURSE DEVELOPMENT MANUAL



October 2018

***Remember, the safety of your passengers and safe operation of the airboat is YOUR responsibility at all times.***

When carrying passengers:

- **Warn passengers to stay clear of the propeller at ALL TIMES**
- Discuss the hazards present in airboat operations before embarking
- Ensure personal gear is stored or properly secured
- Balance the load in the boat (passengers and personal gear)
- Warn passengers not to stand while underway

## Table of Contents

<b>Purpose</b> .....	4
<b>Course Objectives</b> .....	4
<b>Disclaimer</b> .....	4
<b>Chapter 1- Airboat Orientation</b>	
Introduction.....	5
Components of an Airboat .....	6
Hull Design .....	13
Hull Materials .....	13
<b>Chapter 2-Maintenance</b>	
Engine Types .....	14
Aircraft .....	14
Automotive.....	15
Propeller Maintenance .....	16
Pressure Plate .....	19
Reduction Gear Box .....	20
Running Gear and Engine Frame .....	21
Steering Linkage and Rudders.....	21
Electrical System.....	22
Lights .....	23
Exhaust System .....	24
Cooling System .....	24
Trailer Maintenance .....	25
Trouble Shooting .....	26
Maintenance Log .....	27
Skill Development.....	27
Ending Notes on Maintenance .....	28
<b>Chapter 3- Required and Recommended Equipment</b>	
Required Safety Equipment.....	29
Recommended Safety Equipment.....	29
Other Recommended Equipment.....	29
Recommended Spare Parts .....	30
Other Recommended Items .....	30
<b>Chapter 4- Operating Airboats</b>	
Operator Attitudes and Awareness .....	32
Pre-Flight Safety Inspection .....	34
Cold Starting an Engine .....	37
Engine Warm-Up .....	38
Trailing, Towing and Launching .....	39
Dry Launching and Retrieving .....	41
Weight Distribution and Cargo.....	43
Normal Running .....	43
Stopping and Slowing Down.....	44

Execution of Turns.....	44
Counteracting Inertia and Maintaining Control in Turns .....	46
Shallow Water Operations.....	46
Deep Water Operations .....	47
Dry Ground Operations .....	48
Crossing Levees .....	49
Night Operations .....	50
Collision Avoidance .....	51
Obstacles to Avoid .....	52
Getting Stuck and Unstuck .....	54
Swamping and Sinking.....	55
Encountering Other Airboats .....	56
Wind .....	56
Lost or Simply Turned Around .....	57
Knowledge of the Terrain.....	57
Storm Debris .....	58
Considerations for Off-Trail Use.....	58
Operation of Airboats Around Lightning .....	59
<b>Chapter 5- Practical Exercises</b>	
Launching.....	60
Loading .....	60
Docking.....	60
Shallow Water Course .....	61
Deep Water Course.....	63
Docking and Beaching .....	65
<b>Safety Precautions .....</b>	<b>67</b>
<b>Pre-Flight Safety Inspection Checklist.....</b>	<b>69</b>
<b>Float Plan .....</b>	<b>71</b>
<b>Airboat Operation Log.....</b>	<b>72</b>
<b>Example Maintenance Log .....</b>	<b>75</b>
<b>Glossary of Airboat Terms .....</b>	<b>76</b>

## **Purpose**

This is an entry-level course on airboat operation. Airboats are dangerous and can present serious, life-threatening situations at unexpected times to even the experienced of operators.

The airboat is a specialized piece of equipment designed to go where other vessels cannot go. Operating the controls of an airboat is very simple, it just requires throttle and a steering lever, however, intricacies of operating an airboat correctly are complicated and extremely critical.

## **Course Objectives**

By the end of the airboat operator course, the participant should be able to:

1. Describe the operating principles of an airboat
2. Identify the control panel and the purpose of each gauge with respect to aircraft and automotive engines
3. Identify each part of an airboat
4. Conduct a thorough pre-flight safety inspection
5. Perform minimal required maintenance of airboat components
6. Demonstrate how to safely start, stop and turn an airboat in shallow and deep water as well as in semi-dry conditions
7. Demonstrate minimum planing speeds
8. Demonstrate docking, beaching, loading and unloading an airboat

## **Disclaimer**

Neither the authors, advisors, nor the agencies they represent can assume any liability for accidents arising from the presentation of this training material. There are far too many conditions, variables and situations, while operating airboats, to be adequately covered in this basic training module.

## **Photo Contributors**

Brett Billings, Axle Brunst, Amanda Chestnutt, Ryan Hagerty, Steve Hillebrand, Gary Hill, Michael Lusk, Jena Moon, Mike Nance, Ian Shive, Ellen Stutzenbaker, Patrick Walther, American Airboats, Mark's Airboats, Stossel Airboats, Kline Airboats, and Southern Airboats.

# Chapter 1-Airboat Orientation

## Introduction

Airboats are uniquely designed for hauling equipment and people in shallow water areas such as wetlands, swamps, marsh areas, vegetation-choked waterways or semi-dry conditions. Airboats are generally flat-bottomed; aluminum, fiberglass or ABS plastic hull vessels varying from 8–30 feet in length and from 3–15 feet in width with payload capacities up to 7,500 pounds. They are usually lacking floatation material and most are not U.S. Coast Guard approved. The bottom may be stainless steel, aluminum or covered by a protective layer of polymer or polyethylene which reduces friction, allowing the boat to be driven in shallow water, through swamps, over gravel or sand bars and onto the shore.



The engine and propeller are housed at the rear of the boat in a protective cage of tubing and covered in wire mesh. The propellers are either laminated wood or carbon fiber and vary in length from 58” to 90”. The large metal rudders mounted on the cage provide steering. These vessels usually weigh from 2,300 to 3,900 pounds.

Airboats may be powered by either automotive engines (usually 350–502 cubic inch) or aircraft engines (4-6 cylinder Lycoming or Continental) producing 150 to over 300 hp. There are a variety of advantages and disadvantages of each engine type that will be discussed throughout this manual.

Airboats are a unique specialty craft falling in a category between motorboats and airplanes. The vessel is powered by moving air across the propeller blades and guided by controlling the rudders. The propeller is a lifting surface similar to an airplane wing. As the propeller rotates through the air, lift is produced which pulls the propeller forward. This forward thrust is transmitted through the shaft and power train to the engine or “thrust-bearing.” From there the force is transmitted to the hull of the boat. The operator controls the speed of the forward thrust with the accelerator pedal. **There is no reverse and there are no brakes.**

Airboats are a very high maintenance vessel. Aircraft engines can seem finicky and mysterious at times. However, aircraft powered boats have the advantage of being lighter weight, more maneuverable and have a greater initial thrust than automotive engine powered boats when used in shallow and marshy areas. Many field stations currently purchase automotive engines because they are easier and less expensive to service. Automotive fuel is more readily available than aviation

fuel and because automotive engines are bulkier with heavy hulls, they are more stable in deeper water. They also have greater cargo capacity and have more power in dry conditions. Automotive engines are simpler, but have some quirks such as dieseling and overheating.

## **Components of the Airboat**

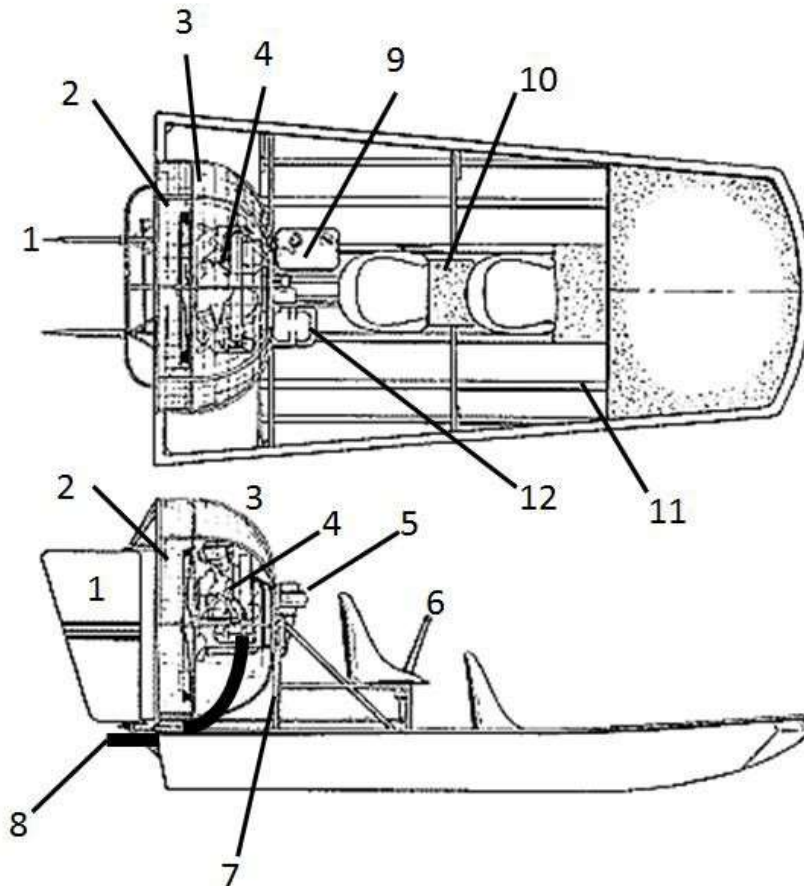

- |                     |                         |
|---------------------|-------------------------|
| 1- Rudder           | 7- Running Gear         |
| 2- Propeller        | 8- Exhaust              |
| 3- Cage             | 9- Fuel Tank            |
| 4- Motor            | 10- Operator's Platform |
| 5- Cooling System   | 11- Reinforced hull     |
| 6- Steering Control | 12- Battery             |



## 1) Rudders

- Are the “steering wheel” for the airboat.
- Typically are light-weight aluminum, hollow inside.
- Connected to the airboat at the transom and cage by linkages.
  - Push-pull cable
  - Heim ball-joint linkages
  - Drag link rods
- Usually, contain the ONLY FLOATATION in an airboat
- “Tracking” can be accomplished by addition of “trim fins”.



## 2) Fan or Propeller

- The airboat is pushed forward by the propeller, which produces a rearward column of air behind it.
- Comes in variety of set ups from simple 2 bladed propellers to several smaller propellers often used in a series of counter rotating propellers.
- Made in a variety of materials and sizes.
- Common materials used for propellers are wood and synthetic material.
- Synthetic propellers are generally hollow, lighter weight, and require less maintenance.



## 3) Cage

- Protects the engine and propeller from debris.
- Protects the operator and crew from engine and propeller.
- Houses the engine, engine stand, fuel tank, batteries and other components.
- Usually covered by 2" x 4" galvanized or stainless wire mesh, spot welded in place over the cage frame.
- Often allows access to engine oil and coolant areas for ease in checking and adding fluids.

## 4) Motor

- There are two common types of engines used in airboats- aircraft engines and automotive engines.

### Aircraft Engines

- Available in 4 or 6 cylinder models for power requirements.
- Lighter weight than automotive engines.
- Typically produce a higher power curve than automotive engines.
- Much more expensive to purchase
- Parts are more expensive and often difficult to obtain.
- Often produce overheating situations due to lack of air flow/cooling.
- Often require specialized mechanics to provide mechanical repairs.
- Adaptable to wooden and composite propeller variations.
- Runs BEST on aviation (AV-GAS) fuel.
- Requires special aviation oil for internal lubrication
- Offers redundant features for reliability in starting.
  - magnetos
  - dual spark plugs at each cylinder

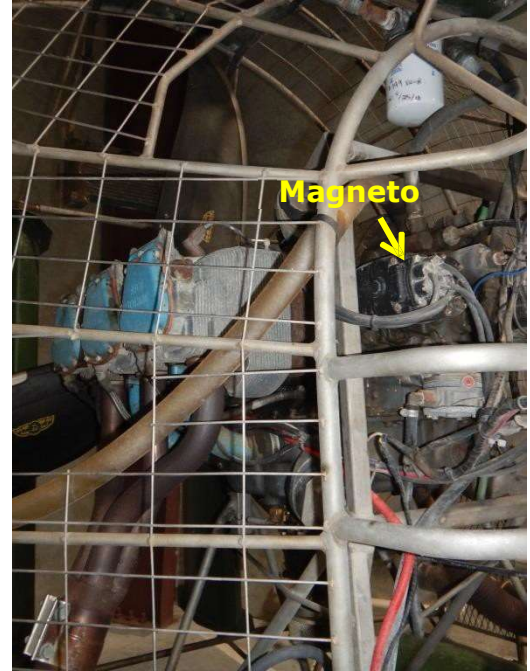

### Automotive Engines

- Less expensive than aircraft engines.
- 350 cu. inch and 454 cu. inch engines are the common choices.
- Often requires a "gear reduction box" to allow maximum performance.
- Easier to maintain, easier to work on
- Parts are readily available.
- Requires radiator for engine cooling.
- Often result in a "top heavy" situation.
- Susceptible to oil leaks at rear seal due to "pusher prop".
- Adaptable to both wooden and synthetic propellers.
- Runs on regular or premium automotive fuels.

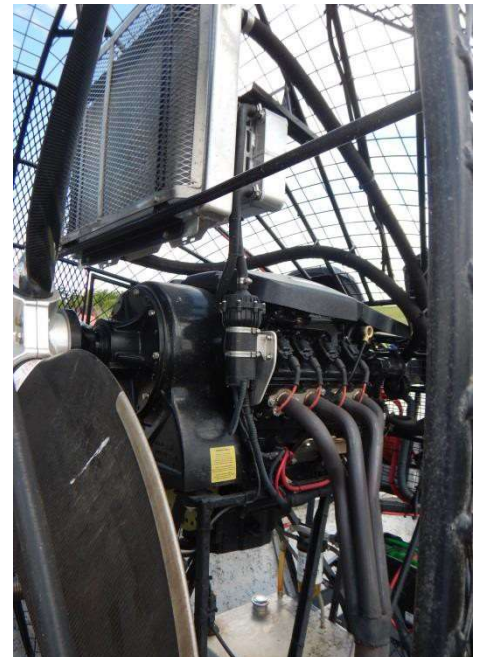



## 5) Cooling System

- A radiator, cold air intake, fan or other cooling device may or may not be present in your vessel.
- Typically aircraft engines are air cooled and thus do not have a radiator; however, they are typically equipped with an oil cooler.
- It is typical to see a radiator and/or auxiliary oil coolers in automotive airboats.



## 6) Steering Control "Stick"

- Steering is accomplished by moving the "stick", located at the operator's side, that is mounted on a series of pivots and linkages.
- Linkages are attached to the rudders.
- Movement is directed as the stick is pulled towards or pushed away from the operator.
- Steering linkages are typically made from rigid conduit or push-pull cables, similar to that found on boat steering systems.



## 7) Running Gear and Engine Frame

- Running gear is the stand that often supports seats, storage, and platforms forward of the cage.
- Stands located inside of the airboat cage are designed to hold the motor and are often heavier duty than the running gear.
- Running gear and motor stands are subject to wear and tear and need regular inspection to ensure safe operation.
- It is not uncommon to find stress cracks or fractures along these support systems.



## 8) Exhaust

- The exhaust carries the by-products of combustion away from the airboat.
- Exhaust tubing is usually made of marine grade stainless steel but can be aluminized steel as well. The exhaust typically is a series of flexible and solid, rigid tubing used with various types of exhaust clamps.
- Automotive style mufflers are installed to reduce engine noise.

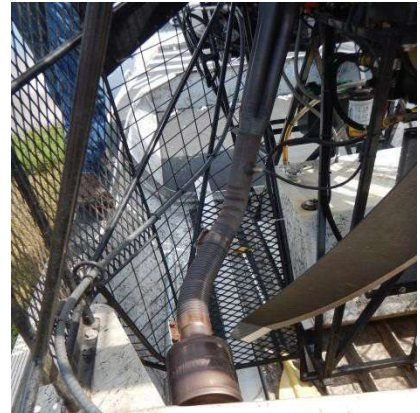

## 9) Fuel Tank

- Typically the fuel tank sits under the motor or just forward of the motor in the airboat.
- It is positioned on the floor of the boat and generally held off the bottom by several supports along the hull of the boat.
- Fuel tanks vary in size but 30-60 gallon tanks are common in most airboats.



## 10) Operator's Platform

- The operator's platform is primarily made for the operator's comfort and support.
- In most airboats the accelerator pedal will be a part of this platform.
- Some platforms may also have a steering bar (similar to aircraft) operated by the operator's feet.



## 11) Reinforced Hull

- Most airboats will have many support braces across the bottom of the boat to provide extra support to the bottom of the boat to mitigate for flexing when running dry ground or heavy seas.



## 12) Battery

- Airboats require a battery for operation
- Some airboats will have a dual battery system.
- A battery is the heart of the electrical system.



## Other Important Components

**Control Panel:** Each airboat control panel has a different configuration, so the operator will need to become familiar with the gauges and switches **PRIOR** to starting the engine. They may include:



**Volt Meter:** Measures the electrical potential in the battery(s). It should read at least 12.5 volts with the key OFF, but should not exceed 14.7 volts.

**Engine Temperature Gauge:** Measures the working temperature of the automotive or aircraft engine and can be used to judge overheating.

**Vacuum Gauge:** Measures engine manifold vacuum; should read 10 inches or above during normal operations.

**RPM Gauge/Tachometer:** Measures engine speed in revolutions per minute.

**Water Temperature Gauge:** Measures water temperature in Fahrenheit and/or Centigrade: (See Engine Warm-Up Section).

**Fuel Gauge:** Measures fuel level in the fuel tank.

**Oil Temperature Gauge:** Measures oil temperature.

**Oil Pressure Gauge:** Measures pounds per square inch (PSI) of oil pressure (See Engine Warm-Up Section).



**Engine Cut-off Switch:** Attached to the operator by a lanyard so the engine will be instantly shutdown in the event the operator is ejected from the boat seat. The engine cut-off switch is optional on an airboat. During operations in areas such as swift currents, large waves or flooded timber, caution should be used to prevent accidental stoppage of the engine.



**Ignition Switch:** Turned with a key for starting the engine.

**Toggle Switch:** Used to manually operate individual electrical components of the airboat (bilge pump, navigation lights, fuel pumps, magnetos, etc.)



**Master Switch:** Many airboats have two batteries and a master switch labeled "Off, 1, 2, All" that is used to shut the electrical system off, isolate batteries so they can be used independently, or used in combination. It is recommended that airboats located in coastal areas or areas where they will be operated often in salt water be outfitted with a master switch and the switch be kept in the "off" position when the airboat is not in use. This will assist in decreasing corrosion over time.





## Hull Design

- Flat bottom
- No keel as in conventional watercraft
- Usually have a rounded, upturned bow as a deflector
- Many airboats will have a grass rake attached to the bow of the boat to move through tall vegetation.

## Hull Materials

### **Fiberglass**

- Common material for today's airboats
- Least expensive material
- Easily repaired or patched
- Relatively light weight
- Usually **NO FLOATATION**

### **Aluminum**

- Common material for today's airboats
- Fairly expensive
- Difficulty in repairs (welding required)
- Considerably heavier than fiberglass
- Potential for electrolysis at attachment points
- Usually **NO FLOATATION**

### **Wood**

- Not used often by today's standards
- Easily damaged by struck objects
- Heavy material (laminated plywood)
- Usually **NO FLOATATION**

### **Stainless Steel**

- Common along coastal areas
- Very expensive
- Difficulty in repairs (welding required)
- Considerably heavier than aluminum
- Potential for electrolysis at attachment points
- Usually **NO FLOATATION**

*NOTE: Each of the above materials will accept the addition of a polymer bottom. Polymer is a composite material, abrasion resistant, with qualities of Teflon. The polymer reduces friction when airboats crossover rough or dry terrain.*

***Right: Polymer on the bottom of an airboat hull***





## Chapter 2- Maintenance

Airboats are a constant source of repair and expense. However, preventative maintenance can save an airboat operator much trouble if completed properly and in a timely manner.

### **Engine Type**

There are basically two types of engines used in airboats: aircraft engines and automotive engines. Both types are similar in their function, but entirely different in general pre-flight safety inspections and starting procedures. Proper maintenance of both types of engines is **critical** to airboat safety and must be followed religiously at all times. Schedules recommended below are to be used as a rule of thumb. Please consult manufacturer guidelines for your particular vessel and running conditions to ensure proper maintenance for your airboat.

#### **Aircraft Engines**

Any major aircraft engine repair work should be done by an aircraft mechanic because of their complexity and specialized tools often needed, but simple maintenance items such as changing oil and cleaning air filters can be performed by the operator.

**Gasoline** – Airboats that are powered by aircraft engines should be fueled with Aviation gasoline (Avgas) available from most airports and occasionally from some service stations. You will find Avgas to be expensive as compared to conventional fuel. Avgas is required to keep aircraft engines running at full power, to prevent knocking or pinging and to keep them from overheating. Avgas has octane ratings from 100 to 120. Premium unleaded automotive gasoline may be used in an emergency, but an octane booster should be added at that time. Continued use of automotive gasoline in aircraft engines **will** shorten the life of the engine.

**Oil** – Oil and the filter should be changed every 20-50 hours of operation depending on manufacturer specifications. A good rule of thumb to follow is to change engine oil every 30 hours. Oil should be changed while warm. The engine can be idled for 10 minutes before removing the bottom drain plug and allowing the oil to drain. Make sure the oil is disposed of properly. Replace the drain plug and fill the crankcase with 50-weight aviation oil (for warm weather operations). Newly rebuilt or new aircraft engines should be “broken-in” with 50-weight, non-detergent castor oil or mineral oil. Thereafter, use 50-weight hi-detergent oil such as Aero Shell. Consult an airboat manufacturer for recommended oil changes in your particular aircraft engine.

**Other Fluids and Filters** – Aircraft engine air filters are usually bottom mounted, screen type filters held in place by 4 bolts. This filter must be removed and cleaned in solvent every 100 hours of operation OR more frequently if operated in areas with large amounts of plant chaff (such as cattail seeds). Water fuel separators are commonly found on most airboats. When changing these filters, it is recommended that you use a marking pen to write the date of installation on the filter as well as making an entry into the logbook.

## **Automotive Engines**

Most automotive engines used on airboats are high performance types with high-compression pistons: steep cam angles and header style exhaust systems.

**Gasoline** – Because they are high performance, premium gasoline from a name brand dealer should be used to prevent advanced detonation of gas due to compression (also called knocking or pinging). Many gasoline dealers add ethanol to their fuel and although it is beneficial in certain ways, it is hydrophilic (attracts water) and degrades certain types of rubber hoses and gaskets making it particularly unsuitable for airboat uses. If gasoline without ethanol is available in your area use this type of fuel in your airboat. You should always use **Premium Unleaded** fuel if possible. Addition of a fuel stabilizer (e.g., Stabil, Seafoam) will also help keep engine parts clean and free from engine build up over time.

**Oil** – Automotive engines, like aircraft engines, require periodic oil changes with filter replacements. Consult the manufacturer or call an automotive supply dealer for a recommended servicing schedule. Oil and filter should be changed every 20-50 hours of operation depending on manufacturer specifications. A good rule of thumb to follow is to change engine oil every 30 hours. When changing the oil, make certain that you allow for extra oil needed to fill the oil cooler and connecting hoses. Make sure used oil is disposed of properly.

**Other Fluids and Filters** – Automotive engines are usually equipped with a replaceable air filter element and should be frequently inspected for clogging. Moisture is a frequent problem with these filters, and they should be replaced when signs of deterioration or wear appear.

Automotive engines require a radiator for cooling. Some airboat manufacturers recommend replacing the standard radiator with a high performance (larger capacity) style and relocating it just ahead of the propeller off the bottom stringers of the boat. Airflow is greater in this location. A quality antifreeze is recommended and levels should be checked during boat inspections. Keep in mind that the relocation of a radiator often will require several extra gallons of coolant due to hose routing.

## **Propeller Maintenance**

Propeller vibration results from damage, uneven moisture accumulation, or warping due to UV exposure and improper positioning during times of storage. If propeller(s) are out of alignment, warped, show significant cracks, de-lamination or have “nicks” larger than a dime, they **must be replaced** or sent to the manufacturer for restoration. Failure to correct these problems **will** lead to engine damage, or worse yet, possible injury to the operator or passengers.

Propellers are subject to damage from debris that collects in the bottom of the cage area. This area should be pressure washed regularly. Any debris left over after washing the boat (e.g., pebbles from gravel roads, bottle caps, etc.) should be vacuumed from the bottom of the boat. Gravel in particular can be very damaging to propellers if not removed.



Propellers should be matched to the boat size and engine weight since improper pitch (angle of the blade) will affect the overall performance. Low RPMs will result in automotive engines not reaching their horsepower output or “energy curve,” further reducing efficiency. In some cases, a mismatched propeller may allow excessive speeds to be achieved or excessive RPMs leading to engine failure. Replacement propellers are available from suppliers listed in the Manufacturer Section of this manual.

Below are specific maintenance recommendations for the most common propellers encountered on airboats. If you have a propeller made of a different material please consult the manufacturer’s recommendations for maintenance.

### **Wooden Propellers**

- The common wooden propeller is often called a “paddle-prop” with its wide, paddle sized blades
- Laminated birch or maple wood propellers are most widely used
- These propellers usually have squared-off tips with protective metal on the tips and leading edges.
- Prices for paddle props are typically in the \$800-\$1,200 range.
- Require significant time and constant attention for proper maintenance

- Must be sanded, sealed with polyurethane or marine grade varnish, and waxed regularly. This will require removing the propeller, light sanding and applying the protective coating.
- The metal end-caps on wooden propellers have small weep holes that should be checked to ensure they are not clogged. Their purpose is to allow an escape route for moisture. This is critical to ensure a balanced propeller.
- Store wooden propellers in a **horizontal** position to prevent moisture migration into the lower blade. Moisture migration **will** unbalance wooden blade propellers.



***Improper Propeller Storage***



***Proper Propeller Storage***

- The mounting bolts should have small holes drilled transversely through the heads so they may be wired together to prevent loosening.
- Stainless steel "lacing wire" is then threaded through the holes, twisted and locked together to prevent the bolts from backing out.

### **Synthetic Propellers**

- The most modern propellers are the multi-bladed, modular synthetic (carbon-fiber) propellers that are bolted to a common mounting plate. Each propeller blade may be removed independently and replaced if damaged or they may be adjusted for varying pitches.
- Require frequent inspection and maintenance.
- Most propellers are attached to the engine crankshaft with multiple bolts, studs, lock washers, nuts and a pressure plate.
- Torqueing the prop to the proper specifications is critical to balancing the propeller.
- When torqueing propeller blades into place be sure to use a torque wrench and set it to the proper foot pounds of pressure.
- *Maintenance Note: In addition to pitch marks on props, an angle finder from your local hardware store can be used to fine-tune pitch of your propeller. Also, silicone caulk can be placed around the area where the propeller and pressure plate meet to reduce water absorption.*



## Examples of Propeller Problems



***Above: Remains of a screwdriver that was forgotten on top of the motor after performing routine maintenance. Damage to propeller and oil cooler.***

***Left: Hairline fracture in the propeller found during airboat pre-flight inspection***

**Right: Wooden propeller exploded when a wave came over the back transom from a misjudged levee crossing attempt.**





## Pressure Plate (Prop Hub)



- The pressure plate (also referred to as a hub or propeller clamp) holds synthetic propeller blade in place.
- The pressure plate serves as a balancing plate when the bolts are torqued in place.
- The pressure plate also requires routine inspection and bolts should be checked every 25-30 hours to ensure they are properly installed and torqued to the proper pressure desired.
- Check manufacturer specifications for torque pressure and bolt type required to properly secure propellers.
- Requires routine inspection for cracks and fractures.
- *Maintenance note: always be sure to set the torque wrench back to zero foot pounds of pressure when finished. Otherwise it will fatigue the spring in the wrench and it may not accurately record pressure in the future.*

### Example of Propeller Hub Problem



**Left: Hairline fracture in the prop hub found during airboat pre-flight inspection.**

## **Reduction Gear Box**

Because automotive engines typically produce higher RPMs, some automotive engines are equipped with a belt drive to a reduction gear, which turns the spindle attached to the propeller. This reduction gear provides optimum torque and propeller speed for normal operation. This reduction gear unit requires grease lubrication, check manufacturer specifications for how much grease is needed and how often. The belt must be inspected for cracking and fraying at each safety inspection, and if damage is found, the belt must be immediately replaced. If the automotive engine is NOT equipped with a reduction drive, particular attention should be given to the crankshaft seal for oil leaks. The propeller, when turning, is placing forward pressure on the crankshaft seal. This condition is opposite in automobiles. If an oil leak is detected, the seal should be immediately replaced.



Another reduction box is also available that is gear driven, eliminating the belt mentioned above. The gearbox is filled with gear oil and should be regularly checked. Refer to your service manual for recommended gear oil change times. As a general rule of thumb, a gear oil change is recommended after 20-50 hours of operation.





## **Running Gear and Engine Frame**

Engine vibration during normal operation causes metal fatigue in the engine mounting bracket, frame welds and engine cages. Metal at these junctions can slowly or abruptly crack when fatigued. All welds should remain painted so when cracks develop the rust line becomes evident and the weld can be repaired. Such cracks are inevitable and close examination to each weld joint should become a routine part of the routine safety inspection. Repairing frame cracks may require that the frame be removed from the boat.



***Cracked Engine Stand***

Because of vibrations from normal operation bolts and nuts attaching the cage and running gear to the boat should be checked every 30 hours of operation. If loose nuts or bolts are found in the bottom of the boat, find the location where they came from. If they are found in the boat, most of the time they belong there and have vibrated loose.

Some airboats are equipped or can be ordered with stainless steel frames and cage frames. Although rusting is somewhat inhibited, cracks still occur due to the vibrations of the airboat.

## **Steering Linkage and Rudders**

Most airboats have a push-pull cable that connects to the control stick. Older airboats may have a mechanical arm linkage connected to the control stick for rudder control. Both styles have zerk grease fittings. Zerks should be greased lightly and often. After greasing, wipe off any excessive grease with a rag. Check all brackets along the length of the linkage for tightness. Avoid sharp bends when installing a new cable. Inspect all weld joints of attachment brackets. The metal sleeves on the push-pull cable are subject to wear and may crack over time. Routine inspection is necessary.

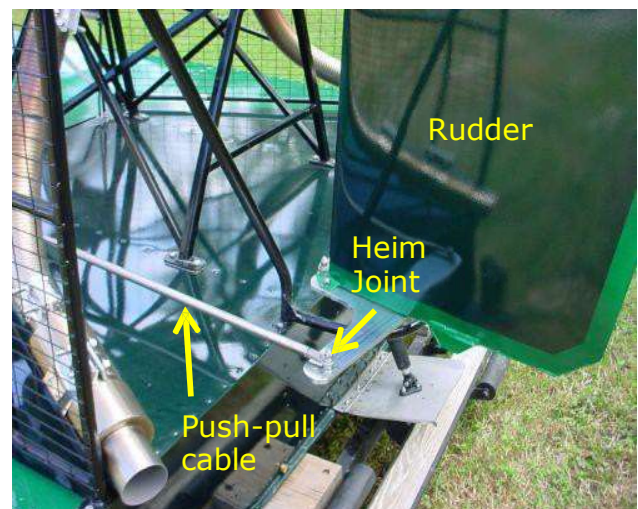

Rudders are usually made of thin-gauge aluminum; therefore, they are easily damaged and relatively expensive to repair. They also extend out an extra 2 feet or

more beyond the transom, so be alert to backing the boat and trailer, crossing steep levees, or of letting a floating boat drift into objects. Rudders are mounted onto the cage and transom, and trailering on bumpy or uneven roads may cause damage. Check these mounting brackets frequently for stress signs. It is best to gently try to move the rudder up and down and forward and backward to ensure that connections are tight. Check for corrosion and pitting around the attachment points of the rudder as well.

## **Electrical System**

Airboats, particularly aircraft engines, require a strong battery to start. The starter motor draws a large electrical current to spin these high compression engines and to whirl the oversized propellers that are always engaged. Airboat electrical systems are probably the weakest link in the entire system, so special attention to battery condition is important. Some airboats have dual batteries and utilize a dual battery selector switch. Most airboats are equipped with a heavy duty 75 ampere

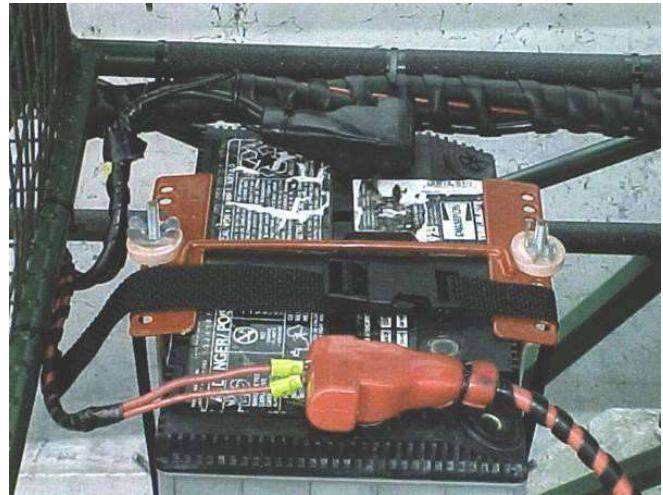

alternator that is capable of charging dual batteries while running, although it is recommended that only 1 battery be charged at a time. Inspect the condition of the alternator belt. Long-term exposure to sun, vibration, weather, and oil will cause belts to become brittle and eventually loosen or break. If this happens while you are underway, you may not know it until you are stuck with a dying engine and no simple way to restart the engine once you turn it off. A spare alternator belt should always be carried in your toolbox.

Batteries are often stored in black plastic battery boxes to protect them from the elements or to prevent shorting. Maintenance-free batteries (such as marine grade gel cell) are recommended as they do not need filling and often will give you a visual indication of their charge status. If refillable batteries are used, evaporation of electrolytes can occur and the water levels in the batteries must be checked regularly. Distilled water should be used to refill the battery. DO NOT overfill beyond the fill mark. Locating the batteries **off the floor** is recommended since a submerged battery will ground out and go dead. In colder climates, batteries may freeze or crack. Storage of batteries in battery boxes will often contain a spill and prevent acid spills onto the floor of the boat. Remove batteries to warmer storage conditions in extreme cold (freezing) weather.

An electrical breaker panel or fuse box is usually the common method of distributing electrical power. Older boats still use the "automotive style" glass fuses or plug in fuses. Newer boats may be equipped with breaker style fuses that can be

re-set by depressing the pop-out breaker buttons or fuses similar to those used in automobiles. Whichever style you have, make sure you carry the appropriate amp fuses as well as an adequate supply of spares in your toolbox.

Most boats are also equipped with a cigarette lighter style outlet for output to spotlights, cell phones, etc. Make sure the outlet is covered to prevent moisture as well as ensuring a heavy gauge wire is used during installation. Many spotlights draw heavy amperage when being used.

If your boat has an automotive engine with a computer, it is recommended to install a battery saver before disconnecting batteries. Also, be sure to disconnect negative terminals first, and positive terminals last. And conversely, when hooking batteries up install positive terminals first and negative terminals last. **Do not mix up terminals** (i.e., hook positive to negative terminals or negative to positive terminals). This can severely damage your electrical system and destroy the wiring harnesses.

## **Lights**

Airboats require the same lighting configurations as motorboats. Please consult Federal, State and Local laws for further guidance on requirements of navigational lights.

Running lights (not navigational lights) are often installed on airboats to light the trail at night. Make sure these lights are installed far enough apart (if mounted on the cage) and properly positioned to provide adequate illumination. Some airboaters mount the lights inside the cage to prevent being torn off by overhanging canopy. If this is the case, make sure all wiring is secured and the light bracket is inspected frequently for tightness.





## Exhaust System

Exhaust clamps, flex tubing, mufflers, mounting brackets and hard tubing should be inspected before each departure to ensure all connections are tight and there are no cracks within the system. Exhaust is particularly vulnerable to vibration and subsequent weakness. Extreme temperatures can influence corrosion of the exhaust system.

*Maintenance Note:* Lubricant (e.g. WD-40 Big Spray, Corrosion X, mineral oil in a spray bottle, etc.) can also be applied to exhaust once dry to extend the life of the exhaust.



## Cooling System



Radiator and oil coolers should be inspected regularly for broken/bent fins and small debris. You can use a pressure washer or compressed air to clean radiators and oil coolers. Care should be used and pressure should be applied lightly to avoid damage to fins of the radiator and oil cooler. They can be easily bent if too much pressure is applied. Ensure coolant in the radiator is filled to an adequate level and anti-freeze is added to the coolant system if needed.



*Maintenance Note:* If you will be running often in areas with wetland plants with small seeds you may consider installing a secondary screen over the radiator using window screen or fine grade hardware cloth. This additional screen will catch and collect small debris and keep the radiator systems clean and working well.

***Bent fins in radiators and oil coolers decrease efficiency over time. These fins were bent by pressure washing at too close a distance.***

## **Trailer Maintenance**

Airboats ride differently on trailers and are subject to increased maintenance needs. Because airboat hulls are shaped differently than conventional watercraft, their trailers must be adjusted to fit the bottom configuration and equally support the weight of the boat. Such support is particularly important with fiberglass hulls. Carpet covered bunks can be adjusted in height to support the bottom over a longer span than can be accomplished with a roller equipped trailer.



1. Trailer attachment must be with the appropriate sized hitch and ball, safety chains and trailer lights.
2. Wash off salt and fouling deposits when you are cleaning the airboat as well as removing all vegetation attached to the trailer.
3. Most of the weight of an airboat is generally carried directly over or right behind the axle of the trailer, which puts additional pressure on trailer tires. Check for proper tire inflation, unusual tire wear and spare tire condition. Tire pressure and wear should be assessed before each trip. Trailer tires must be adequately inflated to prevent overheating and should be balanced to prevent uneven wear.
4. Check the bearings by rocking the boat sideways on the trailer, grease buddy bearings if necessary. Grease often, but do not over grease.
5. Fenders on trailers are also subject to more vibration on airboat trailers and should be checked regularly for cracks and corrosion. Replace as needed.
6. Grease the jack stand lift periodically.
7. The winch stand and bow support on the front of the trailer should be checked regularly for cracks along the welds, especially if the airboat is

- power loaded on the trailer.
8. Ensure the proper winch is installed to support the weight of your vessel and safety chains are in good working order.
  9. Rollers and bunks are subject to damage when power loading so inspect regularly and maintain as needed. Polymer may be applied to trailer bunks and supports to assist in loading. With the boat OFF the trailer, inspect bunk pads, brackets, polymer strips, etc. for stability and security.
  10. Periodically grease winch gear mechanism.
  11. Check for proper trailer light operation...it's the LAW.
  12. Inspect trailer wiring, make sure there are no hanging wires beneath the trailer.
  13. Check trailer manufacturers recommendation for whether to disconnect lights or not prior to launching the vessel. Disconnecting the trailer pigtail can impact the trailer braking system as well.
  14. Make sure there is a padlock on the trailer coupler.
  15. Make sure you have a jack rated for your trailer weight and airboat and a lug wrench that will fit your boat trailer.

## **Trouble Shooting**

Even with the high maintenance required by airboats, often, simple things go wrong. Constant vibrations chafe wires, loosen connections and create a challenge for the operator to constantly troubleshoot. Below are a few hints of things to do:

### **Engine will not turn over**

1. Check the battery master switch and/or battery cable connections.
2. Check operation of key switch or start button with test light.

### **Engine turns over but does not start**

1. Make sure engine cut-off switch is properly connected.
2. Make sure the fuel pump switch is on and is working.
3. **Aircraft engines:** Make sure the choke is **OFF**, make sure Magnetos are on and make sure cylinder gas cut-off lever is pushed in. Check spark at Magnetos; file or replace points if necessary.
4. **Automotive engines:** check spark at spark plugs, check the coil, distributor cap and rotor.
5. If the engine turns over but makes a loud grinding sound, the starter needs to be checked.

### **Engine runs, but you hear a "whistling" sound:**

1. Check intake manifold gasket and replace if blown.
2. Check exhaust system for hole and loose connections.

### **Engine runs rough or suddenly quits:**

1. Check fuel supply and electric fuel pump operation.
2. Check fuel filters.
3. Check water/fuel separator.
4. Check spark plugs, plug wires and connections.
5. Check engine cut-off cord connection.
6. Check ignition switch.

### **Engine is overheating:**

1. **Automotive engines:** Park the airboat with the bow of the boat into the wind and allow to run to cool. DO NOT idle the boat, it should be run at a low RPM to circulate coolant to the radiator system. The boat may be shut down when the temperature gauge is back to the boats normal operating temperature. Once the engine cools, **CAREFULLY** remove radiator cap and check fluid level, inspect entire cooling system for leaks including water pump housing. Check thermostat. Check radiator and oil cooler for debris (small debris may build up over time and need to be removed).
2. **Aircraft engines:** Park the airboat with the bow of the boat into the wind and allow to run at low RPMs until cooled down. Check oil cooler for debris. Check engine oil levels.

## **Maintenance Log**

A maintenance log should be maintained in the tool kit in each boat to record the amounts of fluids used, general repairs and other maintenance records. These are all very important indicators of engine condition. Be sure to record any problems encountered in the logbook and bring them to the attention of those providing service upon return completion of the mission. Hour meter readings should be recorded at times of repairs and pre-flight safety inspections.

Record any unusual circumstances that may have a bearing on future mechanical problems such as noises, vibrations, etc.

## **Skill Development**

During the Maintenance portion of this class, the student should understand and be able to perform the following basic maintenance procedures:

1. Oil and Filter change replacement.
2. Air filter replacement.
3. Simplified propeller tracking and service.
4. Spark plug gap and installation replacement.
5. Alternator/Generator/Fan belt tension and replacement.

6. Lubrication of zerks and related components.
7. Thermostat removal.
8. Reductor box lube change.
9. Sediment bowl removal.
10. Water/Fuel separator.
11. Fuel filter replacement.
12. Use of a torque wrench.

## **Summary**

Although airboats have a reputation for frequent breakdowns, proper maintenance **WILL** reduce problems greatly. **After each use, the airboat should be washed down with fresh water to remove salt residue, mud, sticks and leaves.** The engine should be run after the wash down to dry any components before storage. Protectant spray or rust inhibiting lubricant should be applied to rust-prone areas or parts. Many issues are often located during washing down of airboats, it is a critical step to maintaining your boat.

Note: Information presented in this chapter is meant to be used a general guide, but will not necessarily cover all airboat types nor maintenance needed by each vessel. Know your airboat and manufacturer recommendations for your airboat. Additionally, maintenance guidelines may vary with conditions in which you are operating the vessel and in different climates.





# **Chapter 3- Required and Recommended Safety Equipment**

## **Required Safety Equipment**

It is important to remember there may be differences in equipment, depending on the water body, state and federal requirements, and because of differences in commercial and recreational equipment requirements. It is the boat operator's responsibility to know what equipment is required on their boat.

Each Airboat will have on board, in working and serviceable condition:

1. Navigational lights
2. Fire extinguisher
3. Visual distress signals (if applicable)
4. Sound signaling device
5. Backfire flame arrestor (if applicable)
6. Appropriate PFD's for each person on board

## **Recommended Safety Equipment**

1. First aid kit
2. Adequate hearing and eye protection for each person on board
3. Communications
4. Anchor and adequate line
5. Paddle and/or push pole

## **Other Recommended Equipment**

Airboats are high maintenance vessels. Due to the remote areas of operation, some mechanical aptitude (with the right parts) could prevent an overnight stay in a desolate area.

### **Recommended Tools**

- Pliers
- Channel lock pliers
- Vice grip pliers
- Long-nose pliers
- Cutting pliers
- Phillips and straight screw drivers (assortment)
- Complete combination wrench set (up to ¾")
- Adjustable wrenches (crescent wrenches) to 1.5 inches

- 3/8" or 1/2" drive ratchet and matching sockets
- Spark plug socket (matching your spark plugs)
- Emery cloth (fine grain)
- Fingernail file (point file)
- Feeler gauges
- Electrical test light
- Jumper cables
- Electrical and duct tape
- Tie wire and cable ties
- Engine manual
- Hose clamps- broken welds can sometimes be temporarily fixed with duct tape and hose clamps.
- \_\_\_\_\_
- \_\_\_\_\_
- \_\_\_\_\_
- \_\_\_\_\_

### **Recommended Spare Parts**

- Spare bilge plug
- Electric fuel pump
- Set of points and condenser, spare distributor cap
- Intake manifold gasket and gasket sealer
- Alternator belt
- Spark plugs
- Throttle cable
- Assortment of springs
- Spare oil
- Assortment of nuts, washers and bolts
- 10' lengths of electrical wire
- Spare bulbs for Q-Beam
- Radiator hose with spare clamps
- Spare 1" hose for external cooling system repair
- Spare fuses, bulbs, and dielectric grease
- Spare battery
- Thermostat and a plastic bucket to catch the antifreeze

### **Other Recommended Items**

- Bucket with a lid
- Rain gear
- Spare batteries for headlamps, lights, etc.
- Mosquito repellent
- Sunscreen
- Map of area (sealed in zip lock bag)
- GPS
- Compass
- Rations for two meals per person on board

- Toilet paper
- Drinking water
- Machete (with sheath)
- Parachute or bungee cord, tarp
- Matches in waterproof container
- Extra 12-volt battery
- Wiping rags
- Ratchet style "Come-a-long" and a T-post
- Trash bags or other plastic bags to hold pieces/parts
- Knee boots, hip boots, or chest waders for those times when you have to get out to push, or make repairs.
- Hose or plastic tubing for emergency siphon

Although the above list is relatively short, it is easy to see that you should stock your repair kit with appropriate gaskets, gasket sealer, electrical components, wire and wiring terminals. Always be prepared for emergency repairs in an airboat.

## Chapter 4- Operating Airboats

### Operator Attitudes and Awareness

Many people seem to undergo a personality shift when they take controls of bulldozers, fast cars and airboats. An elation-filled sense of freedom, power and control can cloud your judgment. You feel that you can go anywhere in an airboat...you think it is unstoppable.

Indeed, the most dangerous period for a new airboat operator seems to come with the first flush of confidence, which arrives well ahead of their reflex competence. Eventually, much of the charm of airboat operation is replaced with a caution and a deep realization of the complications and risks associated with their use. Airboats are tools and work platforms to various users. Airboats should never be treated as toys for joy riding or thrill seeking. Remember, you are responsible for the safety and well-being of yourself, your crew, the boat and any damage caused by the boat.



The best airboat operators develop an almost sixth sense of awareness around them. In his book *"A Twist of the Wrist"*, Keith Code uses a motorcycle racer having only 100 cents worth of attention to spend on whatever he or she wants. If one spends 40 cents on fear (or talking to passengers or fiddling with a raincoat zipper) while underway, there is only 60 cents worth of attention for the most important task at hand...driving.

It is helpful to think of an airboat underway as having risk zones of various sizes surrounding the boat as determined by speed and conditions. For example, the operator's attention is directed about 25% on all sides while idling. Attention shifts more to forward and rearward upon acceleration and while underway, it hovers about 90% on reading the upcoming terrain in the path of travel. There is an 80% focus on the outside rear quarter when negotiating slow turns. This "sphere of awareness" is a technique used by airplane pilots and is taught in advanced motorcycle safety courses. It is a very fluid and dynamic way of prioritizing attention, and eventually, develops into a habit. Another feature this incorporates is anticipation and visualization. Training yourself to think ahead and know what to expect prevents surprises and poor, panicked decisions.

Good airboat operators plan on what is going to happen at least 10 seconds before it happens. This is about the amount of time it takes to stop if the conditions are



something they do not want to tackle.

Experienced operators obtain a smoothness and confidence that translates into safer operations, fewer demands on equipment and a reassurance to passengers. Be aware, stay in control and **BE SAFE!**

**Below, are a few "quotes" that many of you may have heard before. Often, these quotes lead to a tragic "WHAT WENT WRONG"!**

- ***THIS AIRBOAT CAN GO ANYWHERE***
- ***I CAN TURN THIS BOAT ON A DIME***
- ***WE CAN RUN DRY GROUND***
- ***THIS BOAT WILL RUN OVER 50 MPH***
- ***THAT GEAR WILL BE OK...IT WON'T BLOW OUT***
- ***LIGHTNING WON'T STRIKE US...WE'RE GROUNDED***
- ***WE DON'T NEED LIGHTS...WE'LL BE BACK WELL BEFORE DARK***
- ***THAT IS JUST A LITTLE DING IN THE PROP***
- ***THIS CELL PHONE WAS SUPPOSED TO WORK ANYWHERE***
- ***DID YOU TELL YOUR WIFE WE MAY BE A LITTLE LATE?***
- ***THIS TRAIL DIDN'T COME OUT WHERE I THOUGHT***
- ***HALF-A-TANK OF GAS IS ALL WE NEED FOR THIS TRIP***
- ***THOSE STRESS CRACKS HAVE BEEN THERE FOR MONTHS***
- ***THE GAUGE IS PROBABLY STUCK***
- ***I FINALLY GOT IT RUNNING...IT'LL BE OK FOR TODAY***
- ***THE ALTERNATOR WILL EVENTUALLY CHARGE THAT OLD BATTERY***
- ***TOOL BOX????? I HAVE MY LEATHERMAN POCKET TOOL***
- ***BILGE PUMP NOT WORKING??? THE PROP WILL BLOW IT OUT***
- ***BUT...I THOUGHT YOU KNEW THIS AREA***
- ***THAT LEAK HAS NEVER BEEN THAT BAD BEFORE***
- ***THAT OLD GAUGE HAS NEVER WORKED RIGHT***

Unfortunately, operators of any equipment often take chances. We want to get finished early. We didn't have the time to get everything done we wanted to. We intend on making a repair before the next trip. We sometimes want to show off a little and impress our friends.

We often take chances that we shouldn't!

Taking a chance in an airboat may lead to events that will leave you stranded in areas that are often isolated and remote.

**BE PREPARED for any emergency.**

## **Pre-Flight Safety Inspection**

Before departure, a Pre-Flight Safety Inspection of the airboat and trailer **MUST BE CONDUCTED**. This enables the operator to find or detect possible deficiencies or shortcomings that will otherwise go unnoticed. All too often, accidents occur because the pre-flight inspection is not conducted. Accidents, injuries and mechanical breakdowns can be avoided by performing maintenance and general inspections of the airboat before operation. This inspection should be performed **PRIOR** to leaving your station, before trailering the boat, as well as a secondary inspection prior to the launch. Often, trailering a boat for miles down a highway or across bumpy roads may create new problems missed during the initial pre-flight safety inspection.

The following is recommended as a **DAILY**, Pre-Flight Safety Inspection. In the rear of this manual is an abbreviated version, suitable for copying as needed.

1. Make sure the **ignition** and **BATTERY SELECTOR SWITCH** (if equipped) is in the "**OFF**" position. It is recommended that the ignition key be removed from the switch during this part of the pre-trip inspection.
2. Inspect the propeller for pits, cracks, nicks and security of mounting bolts. Run your hand over the propeller, it should feel smooth to the touch. The metal end-caps on wooden propellers have small weep holes that should be checked to ensure they are not clogged. This is critical to ensure a balanced propeller.
3. Make a visual inspection of the entire engine area for missing or loose nuts, screws, bolts, etc. If you find a nut, bolt or screw in the cage 99% of the time it has come off of the airboat someplace. Find where it came from and reattach if necessary.
4. Gently shake the cage and rudders to check for tightness.
5. Inspect all wiring for loose connections, as well as evidence of heat damage from the engine. Inspect all spark plug wires as well as Magneto and distributor cap wires. Secure any loose or dangling wires.
6. Check proper and smooth operation of the throttle and all linkages. Where applicable, carburetor mixture control (aircraft engines) should be fixed in the "full rich position" for all operations. Automotive engines are equipped with an accelerator pedal with linkage going directly to the carburetor. If the engine is a fuel injected type of engine the linkage will be attached to the throttle body sensor through a series of linkages generally either wire or cable.
7. Check oil, radiator water, battery fluid and fuel levels. Replenish if necessary, making sure that spilled fluids are wiped clean.

8. Check fan belts and cooling fan blades. Carefully clean (with compressed air or water) cooling fins if necessary.
9. Check oil and fuel systems for leaks as well as vent openings for obstructions. Wipe off any oil sediments or fuel leaks from the exterior. Look for the source of these leaks and correct the problem immediately.
10. For automotive engines, check and clean the sediment bowl if applicable.
11. Leave no loose parts in the bottom of the boat such as washers, nuts, bolts, wire or any debris that can be picked up and thrown by the propeller.
12. Inspect all ball-joint linkages. Those with "zerk" (grease) fittings should be lubricated with a grease gun. Ensure their smooth operation. Avoid over-greasing. Wipe away all extra grease around the fitting. Ball joints without grease fittings should be lightly sprayed with an appropriate lubricant.
13. Inspect rudders for visual damage. Grease "zerk" fittings on top and bottom of rudder mounts. Inspect all mounting hardware.
14. Inspect bilge pump for security. Discharge hose should be secured as well as wiring. Bilge pump housing should be removed and inspected for debris build-up inside. Clean housing and clear discharge hose if necessary.
15. Visually and manually inspect flexible exhaust pipes for security. Look for signs of cracks or discoloration caused by exhaust leaks. Check for loose exhaust clamps. Clamp brackets should periodically be lubricated to prevent rusting.
16. Operate the steering stick to ensure smooth left-to-right rudder operation. Locate any source of binding if present and correct the problem **IMMEDIATELY**.
17. Inspect the entire cage, including all weld joints, attachment bolts and wire covering. Correct any problems **IMMEDIATELY**.
18. **CLOSELY INSPECT** every part of the engine stand and passenger seat stand for broken weld joints. Look for chipped paint, signs of rust or discoloration. These are SIGNS of broken welds. **UNDER NO CIRCUMSTANCES** operate the boat until this problem has been corrected.
19. Inspect battery terminals. Periodically remove battery connections and clean corrosion, lightly oil the terminals and replace.

20. Depress accelerator pedal to "wide-open" and observe response at carburetor. Ensure a smooth movement. Lightly oil linkages.
21. Inspect all eye and hearing protection devices. Make sure they are available for everyone onboard. Make sure you carry spares.
22. Check cargo storage area(s) for loose gear.
23. A push-pole or support boards (1"x8"x12' or 1/2" PVC type pipes) should be carried onboard for assistance in freeing a stuck boat. The boards will give you support while standing on soft mud, vegetation mats or other unstable surfaces. Make sure they are secured properly.
23. **AFTER** the inspection is complete, turn the battery master switch to "ON" and **MANUALLY** operate the bilge pump, navigational lights and electric fuel pump(s) if equipped. Replace light bulbs if necessary. Make sure spare bulbs are carried in parts kits.
24. A detailed **FLOAT PLAN** should be properly filled out before departing on any mission. Airboat float plans should give accurate details to areas of launching, areas of intended use, approximate time on/off the water. You should always establish a contact person to call once the mission has been completed. Things often go wrong and you may find yourself literally stuck in a remote area or with motor problems, leading up to hours before someone notices you are missing.

**ALWAYS** carry a cell phone, satellite phone, and/or radio when you are on an airboat mission. Phones should be carried in waterproof cases.





## **Cold Starting Engine**

Make sure the boat (on a trailer) is **secured to a vehicle with the parking break engaged**, wheels chocked, secure any loose items in the boat, and check behind boat for personnel.

1. Turn the battery selector switch (if equipped) to the "all" or "both" position.
2. Turn the ignition switch to the "on" position. Both automotive and aircraft engines are generally equipped with an electric fuel pump. You should hear the pump run momentarily and then shut off once pressure is attained. Fuel pump – suggest wiring it separate from the ignition to allow the fuel pump to be turned off prior to shutting down the engine.
3. Aircraft and Automotive engines: Pump accelerator pedal **twice**. Pumping more may flood the engine.
4. Aircraft engines only: Some aircraft engines have functional cylinder gas cut-off systems. This system has a valve that closes off gas and fumes entering the cylinder when shutting down the engine. There is a usually a push-pull lever under the operator seat or under the console. This lever needs to be pushed in before starting the engine to allow fuel into the cylinders. When shutting down the engine, pulling the lever out helps

stop the engine and decreases dieseling. Aircraft engines are usually equipped with two magnetos. These are usually turned on/off with toggle switches. **TURN BOTH mag's ON.**

5. Check to make sure the prop area is clear of obstructions and no one is standing near the cage or behind the boat.
6. Turn key switch to engage starter.

## **Engine Warm-up**

1. Do not allow the aircraft engine to operate at more than 800 RPM for the first 60 seconds after starting. This is especially important in cold weather, as the lubricating oil will be slow in circulating. If the oil gauge does not show pressure within the first 30 seconds after starting, the engine should be stopped and an investigation made. Any deviation from this procedure can result in expensive engine wear or serious damage.

2. Above 40 degrees, 1-3 minutes at idle speed should warm-up the engine. At colder temperatures, additional warm up time may be required. An additional 5-15 minutes of running at 800-2500 RPM should be sufficient for warm-up. Extreme cold weather may require additional warm-up time. Watch the gauges.

3. The **oil temperature gauge** (automotive) should read between 170-210 degrees. Aircraft gauges should read between 190-220 degrees.

4. **Water temperature gauge (automotive engines)** should read between 100 to 170 degrees after warm-up and aircraft engines should read between 180 to 225 degrees. (most aircraft engines will not have cooling water. May need to look at cylinder head temp or something else.)

5. **Oil pressure gauge (automotive engine)** should show between 40 to 70 pounds during warm up and no less than 25 pounds during operation. Aircraft engine oil pressure should show about 80 pounds during warm-up and 30 pounds during operation.

6. **Aircraft engine magneto test:** (after initial warm-up) bring the engine up to 1700 RPM. While observing the tachometer, turn OFF the left magneto and observe the tachometer. There should not be more than 150-RPM difference. Turn ON the left magneto, turn OFF the right magneto and again, observe the tachometer.



There should not be more than 150-RPM difference on the tachometer. Return both magneto switches to the "ON" or "BOTH" position (a loss of more than 150 RPM indicates that a magneto is not operating properly). While the engine will run on one magneto, there will be a loss of power and fuel economy.

7. After normal warm up procedures have been accomplished, you are ready to travel to the launch.

## **Trailing, Towing, and Launching**

Trailing airboats requires some forethought. The height of the engine with the cage guard can frequently exceed 10 feet in height. Be cautious of low bridges, gas station awnings, tree limbs, and any other structure you must pass under.



The large cage on the airboat provides substantial wind resistance, so crosswinds greatly influence the stability of towed airboats. Because wind resistance increased greatly with increased travel speeds, it is recommended that 65 miles per hour be considered maximum towing speed.

Some operators have damaged automatic transmissions while towing airboats. Do not use overdrive for towing, and if possible, try to arrange to tow the airboat with a vehicle equipped with an adequate towing package including: reinforced suspension, proper gearing, and adequate cooling systems for engine and transmission.



Polymer bottoms on some airboats make them slide along marsh surfaces as well as off trailers! Some boat trailers have polymer covered bunk supports to aid in unloading and loading the boat. Use caution. It is easy to overshoot the trailer when loading and cause serious damage to the trailer winch stand, rear of vehicle, the airboat, and potentially personnel. **Airboats DO NOT load like a powerboat.**



Airboats can be unloaded or loaded at conventional boat ramps, but always back down very slowly when launching because of the low transom. Watch for the transom to show signs of floating and stop at that point. You should easily be able to unload the boat at that time. Some airboats can also be unloaded and loaded on damp grass or mud, but this requires experience and sometimes a low, tilt trailer. Loading is also dangerous due to the power that is required to initially bring the boat onto the trailer. Again, it is very easy to overshoot the trailer resulting in damage to the boat and vehicle.

Drain plug installation before launching is particularly important on airboats because (1) they have no floatation, (2) access to the drain plug is not possible while afloat and (3) an operator may not attempt to install the plug while the motor is running. Some airboats are manufactured without drain plugs and all excess water must be bailed out, while others have large 2" or greater drain plug holes.



It is not recommended that drain plugs be installed on the outside of the hull. Sticks, limbs and other debris may possibly rip out the plug while the boat is underway. Internally mounted drain plugs **must be** secured with a cord or chain that **prevents** contact with the propeller in the event of becoming dislodged. Carrying two spare drain plugs in the airboat is highly recommended.

***Install drain plugs inside hull and tie to keep from making contact with propeller.***



## Dry Launching and Retrieving

Smaller airboats may be dry launched and retrieved. This is an advanced skill that takes some effort and planning. You will need to find a large flat area that is relatively free from tall vegetation that is near a body of water. Avoid dry launching on pavement, rock roads, or concrete unless necessary. A flat grassy area is best. Dew or recent rain on the grass will be helpful as well.



To dry launch the boat plan the area in which you would like to drop the boat. Pull forward of that area and release winch, safety chains, and stern straps from the airboat. If your vehicle has 4-wheel drive it will be helpful if you put it in 4-wheel drive to dry launch the boat. **Check behind the boat and make sure it is clear of personnel, other vehicles, and other obstructions.** Once you are certain your path is clear, put the vehicle in reverse and move slowly backwards and apply the brakes. You may have to do this several times to get the airboat to slide back on the trailer and eventually onto the ground. **DO NOT USE EXCESSIVE SPEED.** This can result in major damage to the airboat. When executed correctly the airboat will gently fall off the back of the trailer and you can pull forward to clear the remainder of the trailer.

To dry retrieve the airboat, plan your approach carefully. Any small changes in topography can complicate your execution. Have a long flat area free from obstructions between the airboat and trailer. **Do not allow personnel to stand between the trailer and vehicle while you attempt to dry retrieve.** The boat will be loaded under power, but you should be operating at minimal power to make the airboat slide onto the trailer. **DO NOT USE EXCESSIVE SPEED OR OVERTHROW TRAILER.** Also, do not oversteer while on the trailer (i.e., move stick forward and backward). This can rip bunks off of the trailer and cause damage to the airboat. Once on the trailer carefully pull forward to the boat stop.

## Dry Retrieving Example

### Step 1- Plan Execution



### Step 2- Pull forward under power and onto trailer



### Step 3- Carefully pull forward to boat stop.





## **Weight Distribution and Cargo**

Most airboats are generally intended for very shallow water operation. Many airboat designs are somewhat unstable in deep water where mud, vegetation or the hydraulic cushion effects of shallow water do not support their large flat bottom. In deep water (i.e., 2.5' or greater), the angle or attitude of the airboat is changed because of the heavy rear of the boat sinks more than the front, so the propeller thrust is directed more downward rather than a level push. This feature when combined with the high center of gravity due to motor and operator coupled with a low transom means that the craft loses some stability and maneuverability.

Do not overload an airboat. Make sure the weight is equally distributed on both sides of the boat. Watch how deeply the boat sits in the water at various loadings and discuss loading strategies with the manufacturer or experienced operator to estimate safe weight capacities. Loading heavy gear into a bow storage compartment will have a definite effect on how the airboat handles, turns and performs. It is recommended to stow heavy gear as close to the center of the boat as possible.

**REMEMBER:** Most airboats are not U.S. Coast Guard approved and may not have a data plate advising of load or weight capacities.

## **NORMAL RUNNING**



A few lessons are usually sufficient to grasp the fundamentals of operational procedures such as starting, stopping, acceleration and the use of the rudder in steering the boat. Cautious field operation is the most important single factor in safe airboat handling. Over confident operators with years of experience, as well as the beginner, can make costly mistakes. When operating airboats, you will encounter constantly fluctuating surface water levels due to the frequent changes in the terrain. Rainfall, drought and numerous other obstacles such as rocks, mangroves, cypress knees and stumps add to the list of items that affect airboat handling, making operations both difficult and hazardous.

- Do not exceed the recommended cruising RPM for your engine model. When in doubt, consult the manufacturer or a local expert on your staff (e.g., mechanic). Propeller length and pitch also will determine the proper running RPM for the airboat. Gear and personnel loads will affect the performance of the boat.
- While running the airboat, monitor the gauge panel. Gauges should be checked a

minimum of every 5 minutes while the boat is being operated. Any irregularities in RPM, oil temperature, oil pressure, water temperature, voltmeter, or other gauges indicate engine trouble. **STOP THE ENGINE and investigate.**

- Unusual vibrations are an indication of a **SERIOUS PROBLEM. IMMEDIATELY** stop the engine and make a thorough investigation. Inspect for loose engine mounts, a damaged propeller or other problems. Before inspections, **ALWAYS** turn off the battery switch and/or magnetos before proceeding.
- Always provide sufficient airflow for proper engine cooling. Automotive engines often require external oil coolers or relocation of radiators. Aircraft engines often require engine shrouds to maintain proper operating temperatures.
- Note that during acceleration, the propeller's engine torque will cause the boat to tilt. The counterclockwise propeller spin causes the right rear (starboard) quarter of the boat to dip upon acceleration. Watch this dip **CAREFULLY**, because this is the lowest edge of the boat and water may pour over into the boat resulting in swamping of open hulled boats.

## **Stopping and Slowing Down**

After high RPM running, particularly before approaching a dock or landing area, you should allow the engine to sufficiently cool down before stopping. This is particularly important in aircraft engines since they are air-cooled. It is recommended that both automotive and aircraft engines be allowed to run at 800 to 2000 RPM for 2-10 minutes before stopping. Plan your approach accordingly. If the fuel pump is on a separate switch from the ignition, turning off the fuel pump during the cool down period may help reduce dieseling.



## **Execution of Turns**

Due to the gliding ability and speed of an airboat, it is necessary to anticipate turns prior to negotiating them by reducing the speed and obtaining the proper angle to enter the turn. The rate of speed is determined by the sharpness of the turn or obstacles adjacent to the trail. The rudder control stick determines the direction the airboat will travel and the degree to which it is moved forward or backwards determines whether a gradual or sharp turn is made. The amount of thrust provided by the engine also influences the maneuverability by "powering-up" or increasing speed. A sharper, faster turn can be executed. All beginning operators make the mistake of letting off the accelerator completely to slow down for a turn.

Without a constant thrust of air through the rudders, the airboat cannot be steered and it will continue to coast in the direction that inertia will carry it, often for many yards.

Remember, airboats do not have brakes or reverse. Control is maintained ONLY by steering coordinated with application or reduction in power.

1. **Left Turn:** To accomplish a left turn, the control stick MUST BE PULLED BACKWARDS towards the operator. Get into the habit of turning to the left when the boat has to be turned around. (See Deep Water Operation)
2. **Right Turn:** To accomplish a right turn, push the control stick FORWARD, away from the operator.
3. **Turn-Around:** A more advanced turn is the turn-around or 180-degree turn. It can be used when a left or right turn is not possible or desired. A turn-around can be accomplished quickly in a relatively short distance without leaving the trail.



To execute a turn-around, speed is reduced and the control stick is pulled SHARPLY to the rear. As the stern of the boat begins to swing to the right, the bow will act as a pivot point. When the stern has reached the apex of the turn (or come about 90 degrees), power is INCREASED slightly with the control stick in the same position. This will accelerate the turn, causing the stern to whip around completing the 180-degree turn. Inertia will carry the stern forward in the original direction of travel. The operator must “power-up” the engine to sufficiently stop the forward movement of the stern. This becomes important when there is danger of sliding tail first into a tree or obstacle. When the boat stops its forward motion quickly, the bow will nose down and water may splash over the deck from the front or side. This maneuver can be done quickly in shallow water, but in slightly deeper (not exceeding 2 feet) it MUST be done at a slower speed, especially in open decked boats. Too much water hitting the side from excessive speed could swamp the boat or turn it over. Experience and knowing how each airboat responds in turns determines the speed in which a turn-around can be accomplished. Beginners should NOT attempt turn-arounds.



## **Counteracting Inertia & Maintaining Control**

Inertia will cause the stern of the boat to swing to the outside of a turn. In areas of cypress, stumps, rocks or mangroves, this could result in a collision in which the operator could lose control of the airboat. By making turns at a reduced speed, the operator has the ability to “power-up” the engine to overcome the effect of inertia to maintain control. The operator must constantly be alert to where the stern of the airboat is going when making a turn; not only could the hull strike an obstacle, but tree limbs or overhanging objects could damage the cage or propeller.

If it is apparent that the approach to the turn is too fast or at the wrong angle to make the turn safely, the operator should NOT ATTEMPT IT. You should circle around, if possible, and make the turn angle under more favorable conditions.

### ***The Pinball Effect***

The Pinball Effect occurs when an airboat is operated too fast in areas with obstructions (e.g., narrow creek or bayou channels). The operator will attempt to avoid a collision or recover from a side-swipe and will accelerate to compensate. Over-correction will occur and the boat’s stern will swing wide to the other side and side-swipe again. More power is applied to compensate and again, the result is over correcting. This continues, pinball fashion, with the boat careening out of control. Reduce speed in a congested area to avoid the “pinball game”, however, REMEMBER enough air flow must be maintained through the rudders to permit steering and control.

## **Shallow Water Operations**

An airboat is designed to operate in extremely shallow water; as little as a fraction of an inch. As long as there is a continuous coating of water (or moisture) to lubricate the hull, the airboat will operate at its best. When sufficient speed is attained, the boat will lift up and plane on the surface of the water. Loss of plane will result in the hull dragging the bottom in shallow water. Maximum results are achieved when the airboat is maintained on a plane. Moving the rudder stick back and forth slightly while accelerating will break the surface suction and aid in achieving a plane from a dead stop.



Normal cruising speed will typically be 1800-2100 RPM’s for an aircraft engine or 3500-4000 RPM’s for an automotive engine or about 25-30 miles per hour. RPM’s and speed will greatly be affected by boat size, construction, engine size, gear and passenger load. Safe speed is determined by the above conditions as well as operator experience and terrain being crossed.

## **Deep Water Operations**

Sometimes operators must take airboats into deep water when crossing lakes, rivers or canals to get to their destinations. Be aware that in deep water, airboats flip over easily, are prone to take water over the sides or stern, do not take waves well, and are hard to maneuver. Understanding an airboats limitation in deep water can help maintain stability, as can the following tips:

- As discussed earlier, pay particular attention to how your boat is loaded and weight is evenly distributed. Once in water deep enough to float, observe how the boat sits in the water. Adjust or move cargo and personnel accordingly.
- Do not decrease the throttle abruptly while in deep water. Many airboats have been swamped by the trailing wave curling over the transom. This effect is accentuated when stopping during a turn. AVOID stopping in a turn. Turns should be smooth and at a steady speed, performed in the same manner as pulling out of a sharp turn in an automobile. Accelerate on the last part of the turn.



- Airboat turns in deep water are accomplished like a conventional boat, with a wide, curving arc. Beware of entering deep water while negotiating a sliding turn in shallow areas. On flat-bottomed airboats, the sliding edge that encounters the deep water first may catch a chine or build a wave that destabilizes the boat, leading to a series of lunging, sideways hops. The boat may even take water over the leading edge. When the leading-edge digs in, it is called "highside" and the boat may actually flip.

- Pay particular attention to boat wakes while maneuvering in deep water. Gradually slow the airboat down and take the waves quartering rather than head-on. Remember the high center of gravity the airboat has. Entering a wave head-on may lead to the bow submerging. Controlled speed is very important when crossing waves.
- Avoid abrupt stops in deep water. The operator must slow gradually and keep ahead of the stern wake. If the wake overtakes the stern, swamping the boat is likely as the propeller “digs” into the on-rushing water. Splintering of the propeller is likely at this point. The propeller is spinning at over **600 miles per hour** while underway. If water comes over the transom in this manner, you should thoroughly inspect the propeller for damage.
- Left turns, although always not practical, are preferred turns in deep water running. A left turn counteracts engine torque and will reduce the degree of listing.
- **\*REMEMBER SAFETY MEASURES when inspecting ANYTHING behind or inside the cage!**

## **Dry Ground Operations**

When water levels fall, trails at higher elevations in the marsh will develop muddy or dry spots and can become clogged with vegetation. Such conditions can produce suction and drag on the flat hull bottom that will slow and often stop an airboat. A similar effect occurs when running in (or over) thick, tall grass. Forward motion must be maintained when running dry ground. Often, it may be necessary to increase power and/or “zigzag” with the tail rudders to keep moving. Turns that reduce forward speed and increase drag should be kept to a minimum. Running dry ground requires rapid decisions and experience. Can you look ahead and see water? How close is it? Can you initiate a slow, yet deliberate turn that will safely take you back to water? Often, operators may run the airboat too far into dry areas and have no choice but to shut down due to maneuverability problems. Additional power requirements often create overheating problems with the engine.



**CAUTION should be used when considering the need to run dry ground!**



Like dry ground, mud spots require thinking about before attempting. The mud often increases the suction or drag on the bottom of the hull and more power is required to move the boat forward. Is there an alternative route? If I get stuck, HOW do I get out? (See Un-sticking an Airboat). Wet mud or mud with a little water on top may be a very slippery surface for a moving airboat, whereas cracked mud will stop an airboat. Use caution when turning or stopping.

## **Crossing Levees**

Crossing levees may be required for operations in some areas. STOP and access the area before crossing, be aware of potential hull damage, getting stuck, and risk to you and crew. Ask yourself if there is an alternate route?



Crossing levees will require significant power to traverse. To cross a levee, you should prop wash the area to be crossed by pulling near the levee and turning the propeller toward the levee and powering the boat away. This will wet down vegetation and allow you to slide easier over the levee. Idle to the levee and power up just before hitting the toe of the levee. If there is deep water adjacent to the levee a slight hesitation before powering up can push a small wave in front of the boat and help you up and out of the water. Beware of the potential to slide backward down the levee and sink the airboat if you do not make it over the crest.

It is best to hesitate at the apex or top of the levee, and use absolutely as little throttle as required to get the boat to slide down the levee. Boats without solid grass rakes may submarine at the base of the levee when re-entering the water. Extreme caution should be used and you should practice under the guidance of operators with experience before attempting.

## Night Operations

Night operations with an airboat may be necessary. Law Enforcement Officers and recreational fishermen are common on the water at night. You also may find yourself having to return to the ramp after sunset due to engine failure or other boat problems encountered during your work. Whenever the need to operate the boat after daylight, the operator must be prepared for a “different world” on the water. Landmarks used for daytime navigation are no longer visible. Aquatic insect populations become increasingly active at night, often restricting operator visibility and creating serious potential for eye injury. Planing speeds, often required for ease of steering airboats is not safely possible due to limitations of vision at night. If possible, the prudent operator may visit the site during daylight hours and mark or map out areas that may pose dangers or hazards to required nighttime operations.

**WITH LIGHTS:** At night, the operator may opt for a battery-operated helmet light or Q-beam style hand-held light operating off the boat battery system. Some airboats have lights mounted onto the cage above the operator’s head. Without these fixed lights, the operator must constantly sweep the beam ahead of the boat to illuminate the trail. Night speed **must** be reduced to prevent “over-driving” the light and to allow more time to react to situations that develop in the trail ahead. A certain amount of glare will reflect off the deck and back into the eyes of the operator and passengers. You will need to experiment with different angles to get the best illumination possible. Be cognizant that you have one hand on the stick, one hand holding onto the light and your pants holding you in the seat. It can be a dangerous scenario. If you need to put down the light momentarily, remember that the bulb and lens is hot enough to melt plastic and burn skin as well. Be prepared for a bulb burn-out and have spare bulbs and batteries available. It is recommended that you carry a spare 12-volt adapter harness with alligator clips in the event of an adapter plug failure.



Insect populations flourish at night and care should be taken to protect your eyes and your passenger’s eyes as well. Make sure that eye ware is adequate, snug fitting and is adequately ventilated to prevent condensation. Eye protection should be kept clean and properly stored when not in use to prevent lenses from getting scratched. These scratches will greatly magnify when used in night operations.

You may also find that passengers using lights to “assist you” in night driving often



cause loss of night vision and confusion, compounding possible hazards to operations.

Airboat operation at night **without navigation lights** is illegal. A prudent operator should maintain a primary and backup light source in good working condition at all times on the airboat. Backup lights and/or wiring (alternative source) for Q-beams or other light sources is also suggested. There are too many dangers during nighttime operations that make running at night without lights unsafe, unwarranted, impractical and illegal.

As mentioned numerous times throughout this manual, airboats are high maintenance vessels and things **frequently** and **unexpectedly** go wrong. Be prepared with alternative methods of lighting.

*Note: If an airboat will be used often for night-time operations the inside portion of a solid grass rake can be painted black to reduce glare from lights.*

## **Collision Avoidance**

Knowledge of the trail and its hazards and a safe conservative operation of the airboat will prevent most collision accidents. However, due to cross winds, mechanical failure, hesitation to react or other operator error, a head-on collision or side-swipe can occur. It is important for the airboat operator to know: what to avoid, how to avoid it and how to reduce the chances of personal injury or equipment damage if a collision occurs.

Since airboats have no brakes, three courses of action are available if collision is eminent:

- 1. Turn left or right** to avoid the object
- 2. Execute a quick turn-around** or controlled 180-degree turn
- 3. Hit the object**. The type of object hit, its size and the speed of the airboat will determine how much damage, if any, will occur. Generally speaking, a direct, head-on hit is safer than a broadside collision. A last second futile attempt to steer around an object usually results in a broadside crash, which could flip the airboat over if is going fast enough. With any collision, the operators and passengers may be thrown out of the boat or be banged about in the boat. Maintaining a conservative speed in close quarters will minimize the effect of a collision. Whenever practical, hazards should be removed or clearly marked on the trail to prevent the possibility of collisions.

## **Obstacles to Avoid**

**Pond Apple Tree:** Found on the edge of gator holes, in fresh water creeks and “winkeyes”. The pond apple is a small tree with stout, multiple trunks. It will not budge if struck.



**Cypress Trees, knees and stumps:** Very small cypress trees can be hit and bowled over. They will usually break off at ground level. Larger trees and knees (aerial roots) are extremely hard and solid and will cause problems if hit. Cypress stumps are sometimes hidden below the water or in grass near the trail. If the operator allows the airboat to come off plane or wander off the trail in cypress areas, he may get a sudden jolting surprise.

**Mangroves:** Found in or near brackish water and “winkeyes”, their springy roots often protrude into the trail and will either break off, or rebound the boat across the other side of the trail. Smaller mangroves can be run over with no problems; larger ones may cause damage or give a “bronco-buster ride” when the airboat is lifted completely out of the water as it slides over the top of the mangrove and comes down the other side. Also, the boat may become stuck ON the mangrove or its roots and have to be cut out with a machete.



**Rock:** Rock pinnacles are common in the waters of South Florida in the Everglades area. Most airboats using this area are equipped with stainless steel bottoms.



Running on rock is quite hazardous. A broadside collision with a pinnacle rock poses one of the greatest hazards of flipping the airboat.

The rock will also groove a stainless-steel bottom, pop out rivets or worse, rip seams in the hull. Running on rocks should be avoided when at all possible. If pinnacle rock is impacted by the airboat, the hull should be inspected for damage as soon as possible. Rock piles in previously farmed areas are also a common hazard in wetlands.

**Leaning trees:** Make sure that you have sufficient clearance before attempting to go under a leaning tree.

**Flooded timber & stumps:** While operating in flooded or standing timber, you may not be able to maintain adequate steering without adding power. Go slow to minimize damage as you bounce/pinball from tree to tree. Tree stumps that are submerged may take decades to rot. Stumps that are near the water surface will increase your chances of hull damage or flipping the boat if hit while turning at high speed.

**Fence posts:** Many wetland areas were farmed prior to being flooded. In these units, fences may remain “forever” hitting these obstructions may leave you high and dry or with a gash in the hull.

**Sand, Ash, and Cracked Mud:** Sand and sandbars, ash following a wildfire or prescribed fire, and dried cracked mud should be avoided. These substrates will often stop an airboat in its tracks.





**Wildlife:** Killing or harassing wildlife with the careless operation of an airboat is not acceptable. Operators must be constantly aware of the potential impacts on our resources. Deer may dart into the path of an airboat from tall grass or open areas adjacent to the trail. Caution and extreme care should be used during times of water bird and waterfowl nesting and migration. Alligators risk injury or are capable of damaging an airboat if accidentally struck. Constantly be aware of wildlife in your area of work and the impact you may have on them. Ground nesting birds, amphibian, and reptile populations can be impacted by excessive airboat traffic.



## **Getting Stuck and Unstuck**

Getting stuck in an airboat is common. Certain surfaces are capable of **completely** and **immediately** stopping an airboat's forward momentum. The best solution is to learn what types of surfaces to avoid. This usually comes with experience.

If you do get stuck, clear a pathway in front of the boat by removing vegetation, stomping a clear path and wetting it with water. You may also need to stomp vegetation down next to the boat. A 2-5' area should be trampled around the boat. Remove as much weight from the boat as possible. Have the passenger(s) get out and push the boat side to side **while the engine is OFF**.

**Never allow passengers to stand near the cage to push.**

Try using power to rock the boat; pitching the bow side to side. Place PVC pipes or boards under the boat to try and break the suction. Try placing tire inner tubes under the bow and inflate with compressed air to break the suction. If another airboat is nearby, have them "wet" the intended path by driving past in concentric circles. If all else fails, it may be necessary to locate a towing vessel. Un-sticking an airboat with another airboat should be avoided at all costs.

## **Swamping and Sinking**

Should an airboat sink; there are several priority considerations. First, make sure all boat passengers escape the boat and are in safe and stable condition. If at all possible, try and turn the engine off before it submerges. Try and gather **all floating objects**, particularly things important to your rescue. Carefully mark the location of the sunken boat if it is in deep water. If the boat is flipped over, leaking fuel can be a major problem. If it is possible, flipping the boat right side up will control any fuel leaks. There are times when this is not possible, nor practical.



**Swamped Airboat**

**Remember, safety to yourself and the entire crew is most important!**



**Sunk Airboat**

To repair an airboat engine after it has been submerged, the spark plugs must be removed, all fluids should be drained, ignition systems should be dried, the batteries charged and the wiring dried. Depending on the length of submersion, many components of the boat's electrical system may require replacement. Be prepared for future mechanical or electrical failures if **all** electrical components are not replaced after a sinking!

*NOTE: If a boat sinks in navigable waters (any waterway used by other vessels and considered "navigable" by the U. S. Coast Guard) and has to be left unattended, especially after dark, or overnight, the location must be marked. If the vessel is completely submerged, a buoy marker needs to be anchored at the site. A lighted marker is best at night. If the vessel is going to be left overnight, or for any significant time, or unattended during daylight, the U. S. Coast Guard Office, with jurisdiction for that area must be contacted with the location.*



## Encountering Other Airboats

Be aware that you may not be the only airboat operating in your area. Be especially careful when operating around curves or in areas of restricted visibility. Head-on encounters with other airboats in such areas are possible and you must be prepared to avoid a collision. Slow down if you can't see!



It is required to display a flag. Often, this is the only indication you will have of approaching airboats operating in the area. The flag should be a highly visible orange color and should be capable of being lowered and secured during trailering.

Another method of detecting other airboats is to turn off your engine and **listen**. The sounds of other airboats in the general vicinity can easily be heard.

## Wind

Wind can have a profound effect on the operator's ability to steer the airboat. It is **CRITICAL** to be observant of the wind and changes in wind speed and direction such as during an approaching storm.

If wind increases while you are running the airboat, you may have to alter course and head directly into it to maintain control. Winds perpendicular to the rudders cause the greatest instability of control. Often, you may have to tack from one safe turning location to another to get where you want to go.

When traveling with the wind, maintain enough engine power to keep air flowing from the front of the rudders to the back. A reduction of engine power may result in the wind blowing the back of the boat around.

## **Lost or Simply Turned Around**

Any air boater at some time or another will eventually lose bearing, even temporarily, particularly if the operator is running in unfamiliar marsh or areas of tall grasses such as in the Everglades. It occurs by missing a turn, or perhaps being off the trail by a few feet. Sometimes the operator may simply lose sight of the trail temporarily. Flooded trails or drought conditions change the looks of an area dramatically. There are a few things you may do to become re-oriented:

1. **ALWAYS** carry a detailed topo map of the area you are working in. Make sure this map is sealed in a waterproof zip-lock type bag.
2. Stand on the operator seat for a better view. Another 4-5 feet of height may help.
3. Change the boat's position to get a better perspective. Often, backlighting conditions will prevent seeing the trail or marker poles, which blend into the horizon.
4. Retrace your path back to the last known marker, landmark or position on the trail.
5. If lost or disabled, **stay with the boat** and advise the appropriate agency or contact person of your condition and position. If necessary, notify the Fish and Wildlife Conservation Commission, Sheriff Department or Police Department. Your supervisor should be notified and informed of the situation and a logical, safe and coordinated plan should be initiated. The urgency of this plan will be contingent upon the nature of your emergency, adequate food and water, protective clothing as well as the morale of the other passengers on board. This is a situation where the operator, if good and sensible planning was made in advance, will be prepared for this emergency to some degree. **Be Prepared!**



## **Knowledge of the Terrain**

The periods of rising water levels in the summer and declining levels in the winter are periods of inconsistent depth of trail water. Short sections are without water where slight elevations may be covered in heavy grassy areas. Operational know-how is needed to continue to use trails where these conditions are present. (Refer to Shallow Water Operation, Dry Running, Mud Spots, and Deep-Water Operations). Knowledge of the terrain on and along trails and the use of maps, GPS or a compass will assist you in finding your way along undefined areas. To the beginner,

the task of learning trails will seem insurmountable because of the lack of landmarks and the flatness of the terrain. However, with time, hummocks with unusual shapes, trail junctions, cypress stands and sloughs as well as man-made objects will become familiar landmarks and reference points. With experience, a trained eye will be able to distinguish darker colored grass within the trail and its "v" cut through the grass. New operators should learn the trail using these landmarks as well as trail markers.

## **Storm Debris**

In coastal areas hurricane debris can be extremely dangerous, especially when operating in deep water or running cross country on dry ground. Hidden dangers can flip airboats or impale the hull. Similarly, floods can also carry debris into areas where they would not have occurred naturally. Extreme caution should be used following hurricane, tropical storms, and floods.



**This debris was hit following a storm and caused the damage to the hull on the right. The airboat operator was also thrown from his seat during the accident.**

## **Considerations for Off-Trail Use**

Most of the time, air boaters will be using existing trails for getting into and out of work areas. When you have to leave the trail, consider the following:

1. **Minimize habitat destruction.** When off trail use is absolutely necessary, always try to pick routes that go through areas with short vegetation. Tall emergent vegetation, willow heads and tree islands should be avoided to prevent substantial damage. Airboats should be operated at all times to minimize habitat damage.



2. **Off trail use can result in equipment damage** due to stress put on the hull and engine components. **More important** is the never-ending chance of operator or passenger injury.
3. **Destruction of wildlife** frequently occurs when off trail running is used. Many nesting birds, mammals and reptiles use marsh grass for refuge. Be extremely cautious and look ahead for them. We, of all people, should consider our impact on the environment. Airboats can be very destructive in the fact that the hull will flatten out habitat and the prop wash will defoliate trees and bushes. Be cognizant of damage that airboat wake can also produce. You can submerge nests of some species easily with just a few extra inches of water.

## **Operation of Airboats Around Lightning**

Each operator should be aware of the dangers of lightning and instructed to follow proper procedures during times lightning is encountered. Either avoid the storm by changing the route of travel or by waiting for it to pass. If caught in a storm, don rain gear and get out of the boat and away from it (at least 100 yards). If you can get to a shelter, do so. If you cannot get to shelter, try and find a hummock and get under a canopy of dense growth of even height or under other areas of heavy vegetation. Crouch down and wait for the storm to pass. Remember that lightning often comes from the edges of the storm cloud or even out of clear skies near a storm. Hail and heavy rain can be dangerous and unpleasant conditions in which to operate the airboat. When possible park the boat under protection. Check the boat periodically to ensure that the bilge pump will keep up with the water intake.





# Chapter 5- Field Practical

## Launching

Operators and Instructors will work together at the ramp beginning this exercise **ONLY** after Instructor has been assured the airboat is ready to be launched.

1. Boat ramp and end of ramp inspection
2. Drain plug in?
3. Winch strap still in place?
4. Loose gear properly stored?
5. Engine previously warmed up?
6. On-lookers are out of the way?
7. Other boats clear of launch area?
8. Bow line attached and ready for use?

**Instructor will emphasize the importance of the above and following items AGAIN as students prepare for LAUNCHING.**

1. CLEAR COMMUNICATIONS between driver and operator.
2. SLOW backing until transom begins to float
3. Clearing the boat from the trailer with lines or push-off

## Loading

Instructor will emphasize the following areas involved in loading an airboat:

1. Proper trailer depth (**CRITICAL to prevent SWAMPING**)
2. Approach under POWER
3. POWER LOADING vs HAND WINCHING
4. Potential for swamping or sinking
5. Potential for prop wash damage to others

## Docking

Instructor will emphasize the importance of proper docking techniques:

1. Approaching into the wind and current IF possible
2. Approach at slowest speed possible
3. Turning OFF the engine at the right time
4. SAFETY during docking procedures

## Shallow Water Course

This course is designed to be operated on a marsh or mudflat with **no more than 2 inches of water**. It is important to have the area free of obstacles for at least 40 yards around the course. Ten composite safety posts, i.e. Carsonite® posts or ½" PVC pipes are set in the mud at designated distances as shown in the diagram below. The student will be instructed to weave through the course without hitting the markers.

### Shallow Water Course Maneuver 1

At the end of the line the first time through, the student will drive out of the course and comes back to the beginning.

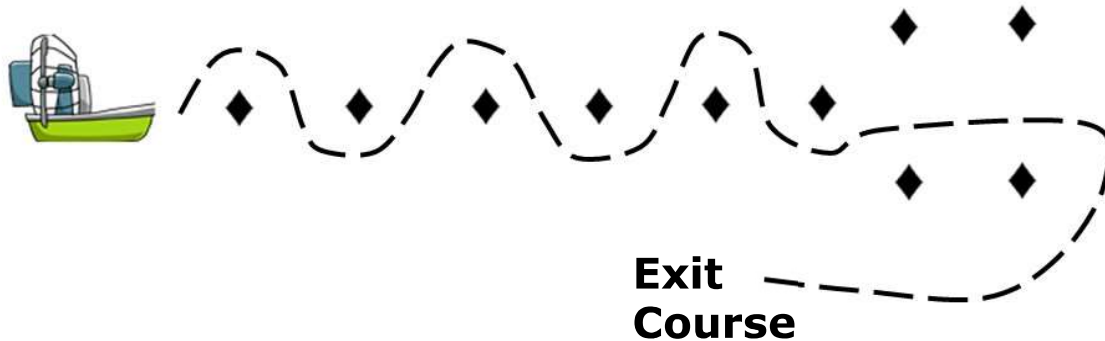

### Shallow Water Course Maneuver 2

The second time through, the student will be instructed to turn around in the "box" and reverse the course

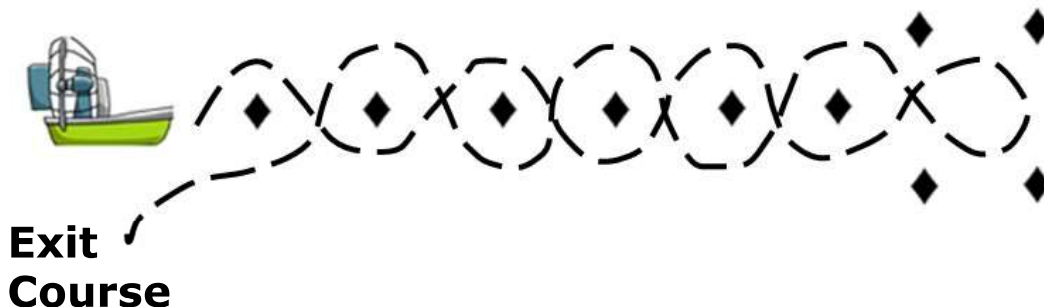

### Shallow Water Course Maneuver 3

During the third maneuver, the student will weave through the course and complete a slow 180-degree turn within the box and STOP.



The student continues the exercise until they can complete it without hitting ANY markers. Most inexperienced operators try and run the course at planning speed. This is nearly impossible if the markers are set close enough. This course trains the student that they will lose control of their airboat if they operate their vessels at high speeds in shallow areas with multiple maneuvering required.

## **Deep Water Course**

This course is designed to be operated in water **3 feet or deeper**. It is important to have the area free of obstacles for at least 40 yards around the course. Eleven composite safety posts, i.e. Carsonite® posts or ½" PVC pipes are set in the mud at designated distances as shown in the diagram below.

### **Deep Water Course Maneuver 1**

For the first maneuver, the student will start at one end of the course and maneuver around alternating markers at a moderate speed. At the first corner post, the student will travel 360 degrees around it, making a complete circle. The student will weave around the marker in the middle and then at the second corner post, complete another 360-degree circle, come out of the maneuver and continue weaving through the remaining markers, ending at the beginning point. This exercise demonstrates the vast difference between mudflats (shallow operations) and deep-water operations as well as the effects of crossing wakes or waves.

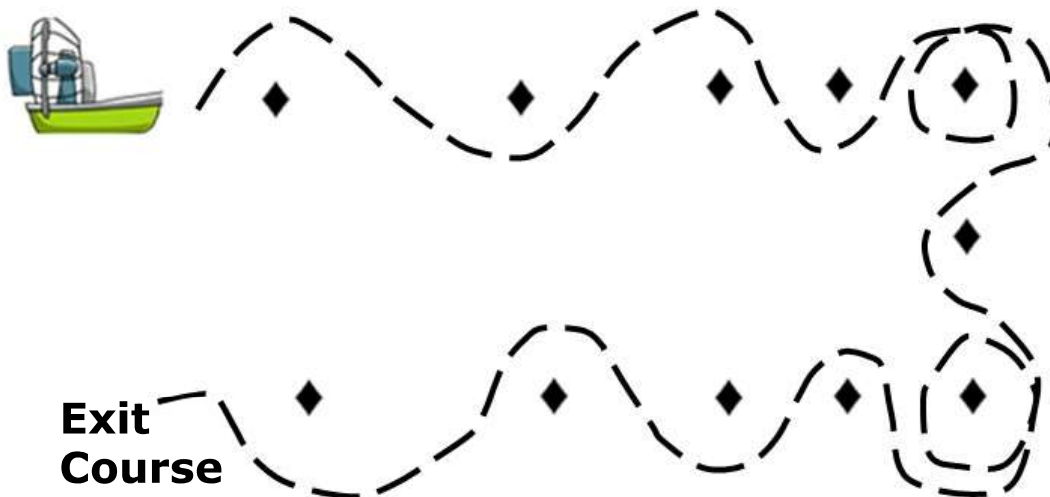



## Deep Water Course Maneuver 2

For the second maneuver, the student will enter the course on a plane at cruising speed. Before reaching the end of the course, anywhere in between, the Instructor will indicate verbally a port (left) or starboard (right) turn. The student at that moment will turn the airboat in the indicated direction, exiting the course at a 90-degree turn without hitting a marker. This course teaches the student how to turn quickly without hitting an object.

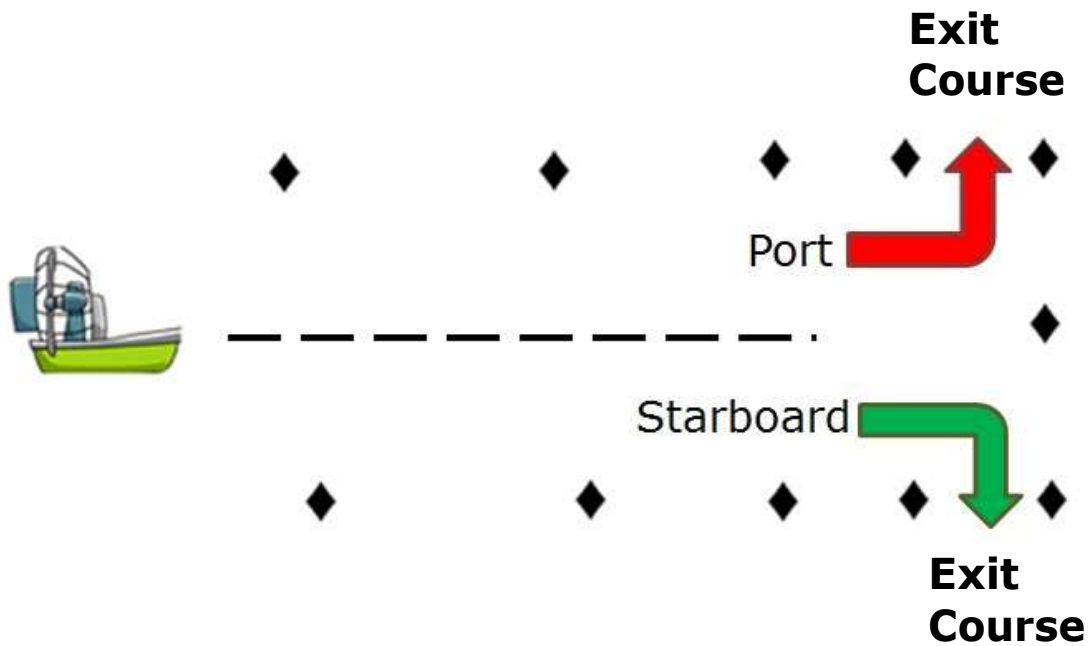

### Deep Water Course Maneuver 3

For the third maneuver, the student will enter the course on a plane or at cruising speed. The student will bring the boat to a complete stop, after spinning the vessel 180 degrees, without getting water over the bow. (See Turn-around). This exercise teaches the student to stop the airboat quickly.

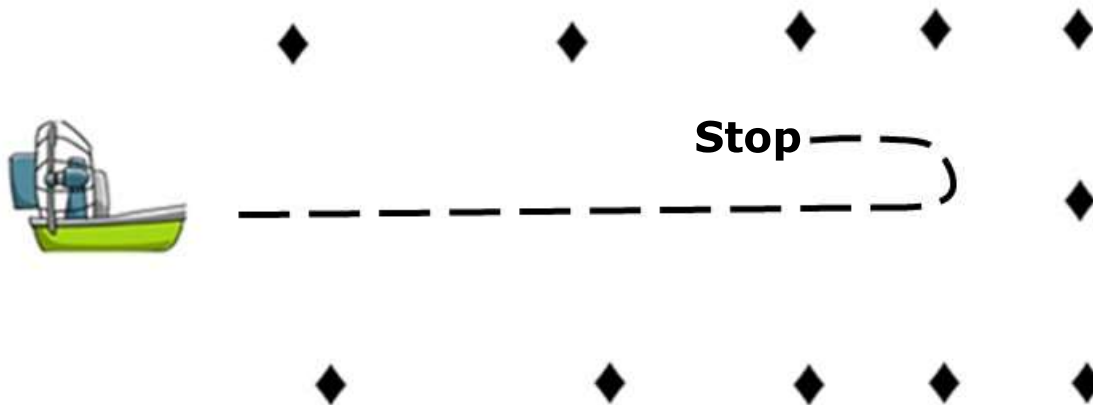

### Docking and Beaching

This exercise is done with a dock, another boat, solidly affixed clump of vegetation or a clear area of shoreline. Any depth of water can be used. Students should first attempt this exercise with an anchored buoy before moving on to the hands-on portion. The student approaches into the wind or current, keeping alert for any hazards or obstructions. The approach should be at the slowest speed possible. Once docked (or in a controllable distance from the dock), the student should turn off the engine. Contact should be made with the dock and momentarily stationed there. The student then notifies anyone in the area that the airboat is about to depart and to shield themselves from any prop wash. The student starts the airboat and begins slowly making a turn away from the dock area. Power (beyond normal idle) should not be applied until the airboat is safely away from the docking area the prop wash has cleared all areas.

Beaching basics should be emphasized for the operator to consider these options as a beaching operation is considered:

1. Incline of the shoreline at the beaching site
2. Water depth at the transom upon stopping the boat
3. Wind and wave action at the transom area
4. Obstructions in and around the area of beaching
5. Ability to push the airboat OFF the beaching area **OR**
6. Ability to POWER OFF the beached area

Choose the beaching area carefully. Make several passes along the area to examine the safest area possible for the airboat, operator and crew safety.

# Safety Precautions

**Always** conduct a Pre-Flight Safety Inspection and a mid-way safety check of the airboat. Just because the boat checked out when you began trailering it to your launch point does NOT mean that things are still the way they were. Check for leaks, unsecured items, debris, loose hanging wires, etc. **Always** turn off the battery selector switch PRIOR to the inspection.



1. Remember, the safety of your passengers and safe operation of the airboat is **YOUR** responsibility at all times.
1. When carrying passengers:
  - a. **Warn passengers to stay clear of the propeller at ALL TIMES**
  - b. Discuss the hazards present in airboat operations before embarking
  - c. Ensure personal gear is stored or properly secured
  - d. Balance the load in the boat (passengers and personal gear)
  - e. Warn passengers not to stand while underway
2. **Always** attach the **engine cut-off switch** lanyard to your PFD during operations, assuming that your activity can be conducted safely with a engine cut-off switch activated.
4. **Always** secure tools after minor repairs. **Immediately** wipe up any oil or fuel spills.
5. **Wear Appropriate Clothing:** Hypothermia is a possibility during cold fronts or rainy periods in winter. Sun and wind burn can be a safety factor. Rubber boots provide more protection than tennis shoes, especially if you have to walk out of a marsh due to boat problems or have to get your boat un-stuck. Hip boots or chest waders will help keep you dry when you need to get out and push.
6. **Always** wear approved safety goggles or approved protective eye-ware. They are designed to protect the eyes from excessive wind and insects as well as bits of grass and debris that is snapped off by the bow of the boat.
7. **Always** wear approved hearing protective devices. Foam earplugs are NOT enough to provide adequate hearing protection. Best results are achieved with a combination of insert foam plugs **and** protective headset type gear. Custom ear plugs can be purchased for those operating airboats regularly.
8. **Always** carry a map of the area you are working in. Keep it in a waterproof container.



9. Hats should be worn snug around the head or secured by a cord to prevent blowing off during operations. Cords, scarves, and hair should be short to prevent their entry into the cage while the engine is running.
10. Spare batteries (cranking) should be secured to prevent spillage.
11. If the airboat handles or sounds different while underway, **stop immediately** and determine the cause of the problem.
12. Monitor airboat fuel levels. Be aware of the consumption rate of your airboat!
13. Operate the airboat in a conservative manner with regard to trail conditions and terrain.
14. Be alert for other boaters at all times. The wake of an airboat can be enough to swamp other boats, and canoes or kayaks may be difficult to see in tall vegetation.
15. Be alert to wildlife hazards such as deer, wading birds, migratory birds and other aquatic wildlife.
16. When checking (running) an airboat on a trailer, ensure that:
  - All loose gear is properly stowed or secured
  - All personnel are clear from the rear of the airboat
  - The trailer is properly secured to a vehicle
  - The wheels are chocked
17. Carry a well-stocked tool kit, adequate spare parts kit and well stocked first aid kit.
18. Carry a cell phone or satellite phone with 12-volt charger.

# Pre-Flight Safety Inspection Checklist

**ALL COMPLETED WITH BATTERIES DISCONNECTED**



AIRBOAT: \_\_\_\_\_ Engine \_\_\_\_\_

Date of Inspection: \_\_\_\_/\_\_\_\_/\_\_\_\_

Inspected by: \_\_\_\_\_

**Check each item thoroughly:**

## **TRAILER**

- Coupler and Coupler Latch operational
- Wiring and Pigtail
- Winch Stand, Winch and Strap, Jack Stand, Safety Chain
- Trailer Frame, bunks and pad inspection (may also be done after each launching)
- Tires and Spare checked for wear and properly inflated
- Wheel Bearings
- Lights operational
- Tag

## **HULL (EXTERIOR)**

- Bow Eye
- Underside Inspection
- Trim Tab
- Rivets or weld joints intact

## **HULL (INTERIOR)**

- Battery Switch (**TURN OFF FIRST**), battery terminals & wiring
- Passenger Seat/Seat Frame Inspection
- Operator Seat/Seat Frame Inspection
- Engine Frame Inspection
- Engine Mounts
- Engine Components: starter, alternator, carburetor, MAGs, filters

- ( ) Cage Inspection
- ( ) Wiring Inspection
- ( ) Rudder/Rudder Assembly
- ( ) Propeller Inspection
- ( ) Linkage(s) Inspection
- ( ) Steering Linkage(s) Inspection
- ( ) Cooling System Inspection
- ( ) Fluid Inspection
  - ( ) Battery(s)
  - ( ) Radiator
  - ( ) Fuel
  - ( ) Oil
  - ( ) Reduction Box Gear Lube
- ( ) Loose items removed/properly stored

**THE ABOVE ITEMS SHALL BE THOROUGHLY CHECKED PRIOR TO  
STARTING THE ENGINE**

## FLOAT PLAN

1. Name of Operator and Telephone Number \_\_\_\_\_

2. Description of Boat: Type \_\_\_\_\_ Color \_\_\_\_\_  
Trim Color \_\_\_\_\_ Number \_\_\_\_\_  
Make \_\_\_\_\_ Name \_\_\_\_\_

3. Type of Vehicle Used \_\_\_\_\_

4. Purpose of Trip \_\_\_\_\_

5. Persons On Board: Names, Ages, Address \_\_\_\_\_

6. Radio Equipment and Frequencies \_\_\_\_\_

7. Communication Schedule \_\_\_\_\_

8. Departure Date and Time \_\_\_\_\_

From \_\_\_\_\_ To \_\_\_\_\_  
Routes and Stops

Expected Return (Date and Time) \_\_\_\_\_

9. Time of Weather Briefing \_\_\_\_\_

10. If not Returned by (Date and Time) \_\_\_\_\_ Call the Coast Guard or  
Notify the Following Numbers

11. Notes \_\_\_\_\_

FWS Form 3-2227  
06/02



# Airboat Operation Log

Operator Name: \_\_\_\_\_

Please print

Mailing Address: \_\_\_\_\_

\_\_\_\_\_  
\_\_\_\_\_

Phone: (        ) \_\_\_\_\_

Date: \_\_\_\_/\_\_\_\_/\_\_\_\_

Location: \_\_\_\_\_ Hours of Operation: from \_\_\_\_ to

\_\_\_\_\_ Total Stick Time: \_\_\_\_\_ hrs Comments: \_\_\_\_\_

\_\_\_\_\_  
\_\_\_\_\_  
\_\_\_\_\_

Date: \_\_\_\_/\_\_\_\_/\_\_\_\_

Location: \_\_\_\_\_ Hours of Operation: from \_\_\_\_ to

\_\_\_\_\_ Total Stick Time: \_\_\_\_\_ hrs Comments: \_\_\_\_\_

\_\_\_\_\_  
\_\_\_\_\_  
\_\_\_\_\_

Date: \_\_\_\_/\_\_\_\_/\_\_\_\_

Location: \_\_\_\_\_ Hours of Operation: from \_\_\_\_ to

\_\_\_\_\_ Total Stick Time: \_\_\_\_\_ hrs Comments: \_\_\_\_\_

\_\_\_\_\_  
\_\_\_\_\_  
\_\_\_\_\_

Date: \_\_\_\_/\_\_\_\_/\_\_\_\_

Location: \_\_\_\_\_ Hours of Operation: from \_\_\_\_ to

\_\_\_\_\_ Total Stick Time: \_\_\_\_\_ hrs Comments: \_\_\_\_\_

\_\_\_\_\_

\_\_\_\_\_

\_\_\_\_\_

Date: \_\_\_\_/\_\_\_\_/\_\_\_\_

Location: \_\_\_\_\_ Hours of Operation: from \_\_\_\_ to

\_\_\_\_\_ Total Stick Time: \_\_\_\_\_ hrs Comments: \_\_\_\_\_

\_\_\_\_\_

\_\_\_\_\_

\_\_\_\_\_

Date: \_\_\_\_/\_\_\_\_/\_\_\_\_

Location: \_\_\_\_\_ Hours of Operation: from \_\_\_\_ to

\_\_\_\_\_ Total Stick Time: \_\_\_\_\_ hrs Comments: \_\_\_\_\_

\_\_\_\_\_

\_\_\_\_\_

\_\_\_\_\_

Date: \_\_\_\_/\_\_\_\_/\_\_\_\_

Location: \_\_\_\_\_ Hours of Operation: from \_\_\_\_ to

\_\_\_\_\_ Total Stick Time: \_\_\_\_\_ hrs Comments: \_\_\_\_\_

\_\_\_\_\_

\_\_\_\_\_

\_\_\_\_\_

Date: \_\_\_\_/\_\_\_\_/\_\_\_\_

Location: \_\_\_\_\_ Hours of Operation: from \_\_\_\_ to

\_\_\_\_\_ Total Stick Time: \_\_\_\_\_ hrs Comments: \_\_\_\_\_

\_\_\_\_\_

---

Date: \_\_\_\_/\_\_\_\_/\_\_\_\_

Location: \_\_\_\_\_ Hours of Operation: from \_\_\_\_ to

\_\_\_\_\_ Total Stick Time: \_\_\_\_\_ hrs Comments: \_\_\_\_\_

---

---

---

Date: \_\_\_\_/\_\_\_\_/\_\_\_\_

Location: \_\_\_\_\_ Hours of Operation: from \_\_\_\_ to

\_\_\_\_\_ Total Stick Time: \_\_\_\_\_ hrs Comments: \_\_\_\_\_

---

---

# Airboat Fuel, Hours, and Maintenance Log

<b>Date</b>	<b>Name</b>	<b>Boat</b>	<b>Hours (Start)</b>	<b>Hours (End)</b>	<b>Fuel Used</b>	<b>Oil Added</b>	<b>Oil change?</b>	<b>Problems, Comments, Maintenance (Attach detailed notes if needed)</b>



## Glossary of Airboat Terms

<b>Airboat</b>	A boat that is propelled by air thrust from a motor driven propeller
<b>Avgas</b>	High-octane (110-120 octane) fuel used in most aircraft engines
<b>Bendix Gear</b>	The retractable gear and spring mechanism attached to the spindle of the starter motor
<b>Buddy Bearings</b>	Spring loaded caps that maintain pressure on the grease in wheel bearings
<b>Cage</b>	A shield of welded tubular metal and welded wire that encircles the airboat motor and propeller
<b>Chine</b>	The angular intersection of the bottom and sides of a boat
<b>Composite Propeller</b>	A durable but expensive propeller made of synthetic materials, usually layers of carbon-fiber. They replace the conventional laminated wooden propellers and may be set in arrays of 3, 6 or more on a central spindle
<b>Dieseling</b>	An undesirable run-on of the engine after the ignition key has been turned off. Dieseling occurs most often in high-compression, hot engines as they continue to suck fuel in and combust it from heat and compression. It is destructive to engines. Turning off the fuel pump at least one minute prior to engine shut down may reduce or eliminate dieseling.
<b>Float Plan</b>	A comprehensive list of boating locations, dates, passengers, time on/off the water and contact persons to be notified in the event of an emergency
<b>Friction Plate</b>	The metal disc through which the propeller bolts extend. This plate provides the friction that holds the propeller onto the engine drive shaft. It should be tightened (torqued) to factory specifications
<b>Highside</b>	Catching the edge of a boat while sliding sideways. It may lead to violent hops or turning over
<b>Hull</b>	The sides, bottom, transom and supporting chines of the airboat

<b>Magneto</b>	A high energy capacitor mounted on aircraft engines. The "mags" provide the electrical current burst to the spark plugs, which ignite the gasoline charge in the cylinder. The magnetos must be shorted out (turned off) with the mag switches to stop the engine
<b>Paddle Prop</b>	A large style (usually wooden) propeller designed for maximum propulsion at typical airboat speeds
<b>Pitch</b>	The amount of angle or twist of the propeller blade. Pitch, diameter and configuration of the propeller determine its performance and must be matched to the boat and engine
<b>Plane</b>	The effect of boats rising up onto the surface of the water once a determined speed is achieved. A boat may motor through the water slowly, or "plane-out" by moving rapidly along the surface of the water much like a waterskier. Once a boat is on plane, handling characteristics change dramatically
<b>Porpoising</b>	The rhythmic bobbing of a boat in which the power source is not parallel to the water's surface. Loading improperly, speed, and wind resistance or trim tab angle will change the attitude of the boat. Porpoising is undesirable and immediate corrections should be taken to eliminate
<b>Prime</b>	An initial trace of gasoline to help engines start. Aircraft engines usually have their carburetors below the engine and assistance in pumping fuel to the cylinders is provided by an electric fuel pump or a piston attached to the throttle linkage
<b>Prop Wash</b>	The column of air emitted rearward from an airboat propeller
<b>Red Line</b>	The mark on an engine's speed gauge (tachometer), indicating the maximum safe RPM's. Engines should not be operated near the red line except in rare short bursts of energy when maximum power is needed
<b>Reduction Gear</b>	Pairs of gears (sometimes belt driven) on the rear of airboat automotive engines. This reduction gear aids in matching automotive RPM's to larger "power" propellers for maximum power outputs. Reduction gear equipped airboats are often referred to as the 4x4 of the airboat world

<b>RPM</b>	Revolutions per minute. This is a measure of engine speed indicated by the number of times the engine crankshaft spins around its axis per minute
<b>Rudder</b>	The airfoils fin or fins mounted behind the airboat propeller and attached to the steering control stick by a cable or rod. The rudder provides directional control by directing the propeller's air flow in the opposite direction of the desired movement of the rear of the boat
<b>Sprayer</b>	A pressurized hose and nozzle arrangement designed to spray a slippery liquid solution onto the boat's hull to reduce friction and permit the hull to slide over obstacles
<b>Stick</b>	The lever used by the airboat operator to steer the airboat. Attached by cables or linkages to the transom and rudder linkages of the airboat
<b>Tachometer</b>	A primary gauge that indicates the rate of spin of an engine. (See Red Line)
<b>Teflon</b>	A hard, slippery, plastic-like polymer (not true Teflon) material. When sheets of polymer are attached to an airboat hull, it permits easier sliding over obstacles with less resistance
<b>Transom</b>	The rear wall of an airboat hull. That portion of the boat behind the propeller. Airboat transoms are usually lower than conventional boats to permit maximum thrust to escape from the propeller
<b>Trim</b>	The angle of the boat in the water. Important for proper forward speed and handling. (See porpoising)
<b>Trim Tab</b>	Adjustable plate(s) either hydraulic or spring loaded, mounted on the hull transom that affects water resistance and can be used to adjust the trim of the boat to enhance control and performance
<b>Zerk fitting</b>	A small metal, self-sealing nipple fitting into which grease is pumped to lubricate moving parts

## **All courses should include the following content, as required by the Florida Fish & Wildlife Conservation Commission (FWC)**

- Florida specific boating requirements.
- Florida's adoption of all federal equipment requirements.
- Ecosystem Awareness, based on local issues.
- Boating accident requirements – remaining on scene; rendering assistance; reporting accidents.
- Problems seeing other vessels and being seen by them.
- Boating Restricted Areas and Regulatory markers including Idle Speed, Slow Speed, and mile per hour restrictions.
- Operator responsibility (ethics), courtesy and good judgment on the water.
- Avoiding careless, reckless, and negligent operation of vessels.
- The effects of alcohol, controlled substances, and stressors.
- Navigation Rules including maintaining proper lookout, safe speed, and requirements of give way or stand on vessels.
- Aids to navigation; buoys and other waterway markers.
- Awareness of changes in weather or water conditions and proper responses to those changes.
- Boating accidents including causes and prevention of airboat accidents.
- Noise, nuisances, environmental and other operational concerns.